

# MODEL SR1060

## Resistance Transfer Standard System

Instruction Manual

Part Number 58619D

November 1987

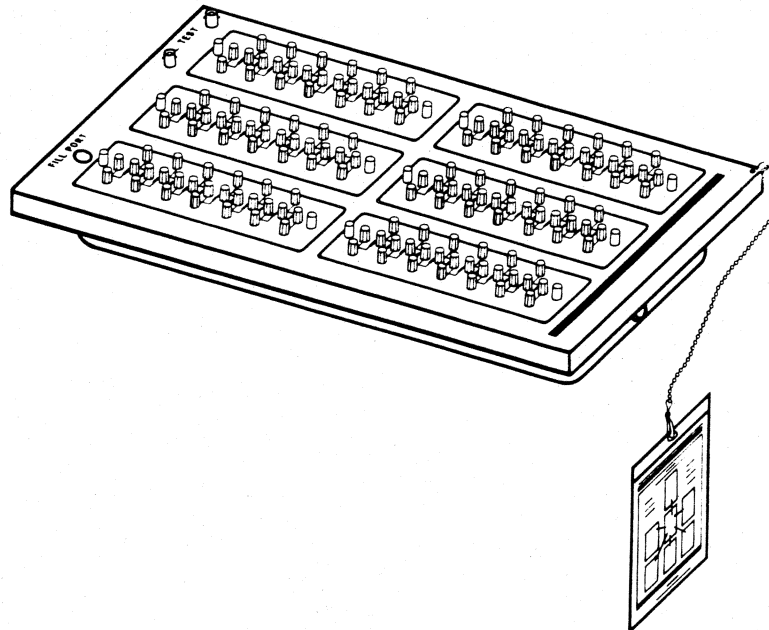

Electro Scientific Industries, Inc.

13900 N.W. Science Park Drive • Portland, Oregon 97229 • Telephone: (503) 641-4141 • Telex 4742064

©Copyright 1986 Electro Scientific Industries, Inc.  
All rights reserved • Litho in U.S.A.

ESI® reserves the right to change specifications  
and other product information without notice.

ESI and KELVIN KLIPS are trademarks of Electro Scientific Industries, Inc.

## TABLE OF CONTENTS

1	General Information	
	1.1 Introduction	1-1
	1.2 System Description	1-2
	1.3 Resistance Transfer Method	1-4
2	Specifications	
	2.1 SR1060 Specifications	2-1
	2.2 Options Specifications	2-3
3	Operation	
	3.1 Connections	
	3.1.1 Series Connections	3-1
	3.1.2 Parallel Connections	3-1
	3.1.3 Series-Parallel Connections	3-4
	3.1.4 Voltage Divider Connections	3-7
	3.2 Thermometer Well	3-9
	3.3 High Accuracy Calibration Transfer	3-11
	3.3.1 Comparing Nominally Equal Values	3-12
	3.3.1.1 Interchange Method	3-14
	3.3.1.2 Substitution Method	3-14
	3.3.2 Primary Resistance Standards	3-15
	3.3.3 Calibration Transfer Between SR1060 Transfer Standards	3-16
	3.3.4 Calibration Transfer Between Principal Resistor Configurations	3-18
	3.3.5 Calibration Transfer to Individual Resistors	3-20
	3.3.6 Calibration of an SR1060 as a Ten-Step Divider	3-22
	3.4 Calibration Card	3-23
	3.4.1 Calibration Procedure	3-24
	3.4.1.1 First Method	3-26
	3.4.1.2 Second Method	3-26
		3-30

## TABLE OF CONTENTS (Continued)

4	Theory	4-1
	4.1 Junction Resistance	4-4
	4.2 Insulation Resistance	
	4.2.1 Derivation of Series Circuit Leakage Resistance Effects	4-5
	4.2.1.1 Series Circuit with Floating Terminal 3	4-11
	4.2.1.2 Series Circuit with Terminal 3 Connected to Terminal 1	4-12
	4.2.1.3 Series Circuit with Terminal 3 Connected to Terminal 2	4-13
	4.2.1.4 Series Circuit with Terminal 3 Guarded	4-13
	4.2.2 Derivation of Parallel Circuit Leakage Resistance Effects	4-14
	4.2.2.1 Parallel Circuit with Floating Terminal 3	4-15
	4.2.2.2 Parallel Circuit with Terminal 3 Connected to Terminal 1	4-16
	4.2.2.3 Parallel Circuit with Terminal 3 Connected to Terminal 2	4-16
	4.2.2.4 Parallel Circuit with Terminal 3 Guarded	4-16
	4.3 Transfer Accuracy	4-20
	4.4 Compensation Networks	4-25
	4.5 Linearity Deviation	
5	Applications	5-2
	5.1 ESI Model 123 Resistance Comparison System	5-2
	5.1.1 System Description	
	5.1.2 Transfer from 10 kilohms to 100 kilohms and 1 kilohm	5-4
	5.1.3 Transfer from 10 kilohms to 100 ohms	5-6
	5.1.4 Transfer from 10 kilohms to 10 ohms	5-7
	5.1.5 Transfer from 10 kilohms to 1 ohm	5-11
	5.2 ESI Model 242D Resistance Measurement System	5-14
	5.2.1 System Description	5-14
	5.2.2 Equipment Required	5-15
	5.2.3 Detailed Procedure	

## TABLE OF CONTENTS (Continued)

6	Installation, Repair, and Maintenance	
	6.1 Installation	
	6.1.1 Unpacking	6-1
	6.1.2 Mounting the SR1060 on the Optional Cart	6-1
	6.1.3 Filling the SR1060 with Oil	6-2
	6.1.4 Installing the Calibration Card	6-4
	6.1.5 Initial Checkout	6-7
	6.2 Repair	
	6.2.1 Returning a Resistor Bank for Repair	6-8
	6.2.2 Installing a Single Resistor Bank	6-9
	6.3 Maintenance	
	6.3.1 Checking Resistor Accuracy	6-15
	6.3.2 Maintenance of the Oil	6-17
	6.3.2.1 Testing the Oil for Contamination	6-18
	6.3.2.2 Changing the Oil	6-18
	6.3.2.3 Disposing Contaminated Oil	6-19
	6.3.2.4 Purchasing Oil	6-20
	6.3.2.5 Cleaning Up Spilled Oil	6-20
	6.3.2.6 Material Safety Data Sheet for Oil	6-21
		6-21
7	Parts Lists	
	7.1 SR1060 (P/N 31060)	
	7.1.1 Parts List	7-1
	7.1.2 Parts List	7-2
	7.2 Accessory Kit (P/N 59871)	7-3
	7.3 Options	7-4
		7-4

# LIST OF ILLUSTRATIONS

Fig. No.	Title	Page
	SR1060 Resistance Transfer System	1-0
1-1		3-2
3-1	Connecting Five Resistors in Series	3-3
3-2	Equivalent Circuit of Series Connection	3-4
3-3	Four-Terminal Parallel Connection with Compensation Network	3-5
3-4	Four-Terminal Parallel Connection with Shorting Bars	3-6
3-5	Two-Terminal Parallel Connection with Shorting Bars	3-7
3-6	Series-Parallel Connection with Shorting Bars	3-8
3-7	Series-Parallel Connection with Compensation Network	3-9
3-8	Voltage Divider Connection	3-10
3-9	Voltage Divider Connection with Lead Compensator	3-11
3-10	Location of Thermometer Well	3-24
3-11	Calibration Card	3-29
3-12	Completed Calibration Chart	3-32
3-13	Calibration Chart	4-1
4-1	Resistor Configuration	4-2
4-2	Four-Terminal Junction	4-2
4-3	Measuring Transresistance	4-4
4-4	Effects of Leakage	4-5
4-5	Transforming Between "T" and "Pi" Networks	4-6
4-6	Grouping for the First Transform	4-6
4-7	First "T" to "Pi" Transform	4-7
4-8	Result of First Transform	4-7
4-9	Second "T" to "Pi" Transform	4-8
4-10	Result of Second Transform	4-8
4-11	Third "T" to "Pi" Transform	4-9
4-12	Result of Third Transform	4-9
4-13	Fourth "T" to "Pi" Transform	4-10
4-14	Result of Fourth Transform	4-11
4-15	Series Equivalent Circuit with Floating Terminal 3	4-14
4-16	Parallel Configuration with Leakage Resistances	4-14
4-17	Parallel Configuration Simplified	4-15
4-18	Parallel Equivalent Circuit with Floating Terminal 3	4-20
4-19	Parallel Connection with Shorting Bars and Compensation Network	4-22
4-20	Measuring $r/R$	4-24
4-21	Measuring the Bridge Unbalance	5-2
5-1	ESI Model 123	5-15
5-2	Generator-Detector Dial Settings	5-16
5-3	Lead Connections	5-17
5-4	Bridge Dial Settings	5-18
5-5	Resistance Standard Dial Setting	5-19
5-6	10 ohm Standard Resistor Connections	5-19

## LIST OF ILLUSTRATIONS (Continued)

Fig. No.	Title	Page
5-7	System Calibration at 10 ohms	5-20
5-8	100 ohm Resistor Bank Calibration at 10 ohms	5-22
5-9	Lead Connections to the SR1060	5-24
5-10	Deviation Measurement	5-26
5-11	Calibration at 100 ohms	5-28
5-12	Lead Connections	5-30
5-13	System Dial Settings	5-31
5-14	Measurement of Resistor R10	5-32
5-15	Lead and Network Connections	5-33
5-16	Lead Connections	5-34
5-17	Series-Parallel Deviation from R10	5-35
5-18	Bridge Calibration at 100 ohms	5-36
5-19	SR1 Calibration	5-38
5-20	Calibration of 100 ohm SR1	5-39
5-21	Bridge Calibration at 1 kilohm	5-40
5-22	Bridge Calibration at 1 kilohm	5-42
5-23	Calibration of 1 kilohm SR1	5-44
5-24	Calibration of 1 kilohm SR1	5-45
5-25	Resistance Transfer Data Sheet	5-46
6-1	Installing the SR1060 on the Optional Cart	6-3
6-2	Location of the FILL PORT	6-4
6-3	Siphoning the Oil	6-6
6-4	Installing the Calibration Card	6-7
6-5	Location of OIL TEST Connectors	6-8
6-6	Resistor Bank Packing Box	6-10
6-7	Removing the Resistor Bank Screws	6-11
6-8	Packing the Resistor Bank	6-12
6-9	Taping the Resistor Bank to the Packing Box	6-13
6-10	Plate to Replace Resistor Bank	6-14
6-11	Sequence for Tightening the Resistor Bank Screws	6-16
6-12	Location of the FILL PORT Plug and Drain Plug	6-19

## LIST OF TABLES

Table No.	Title	Page
3-1	Recommended Calibration Transfer Sequence	3-19
4-1	Model 801B Settings for Transresistance Measurement	4-3

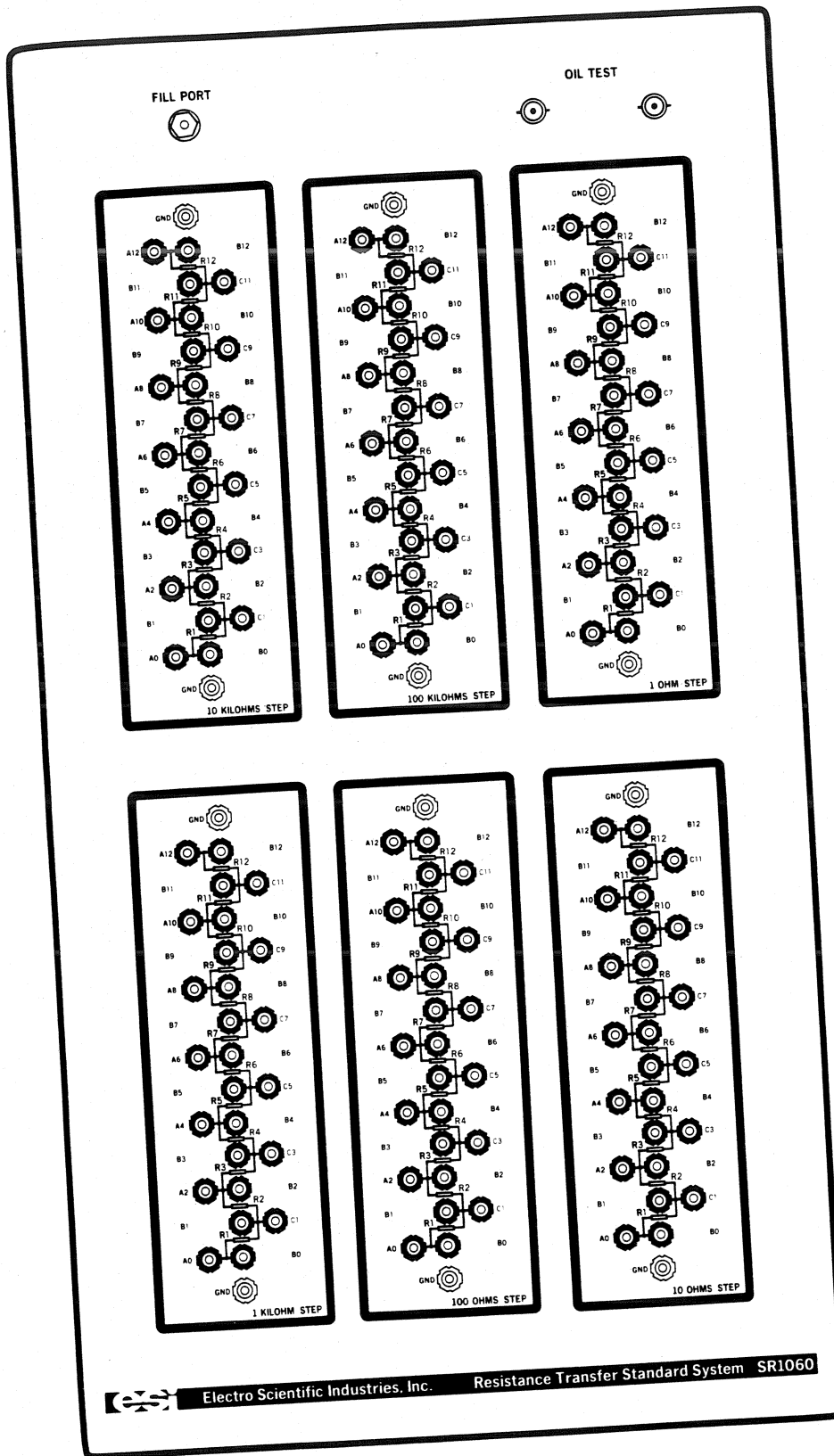

Figure 1-1. SR1060 Resistance Transfer System



# SECTION 1

## GENERAL INFORMATION

### 1.1 INTRODUCTION

This is the instruction manual for the Model SR1060 Resistance Transfer Standard System. It provides complete information about the installation, operation, performance, and maintenance of the System.

**NOTE:** The term "SR1060" will be used in place of "Model SR1060 Resistance Transfer Standard System" in this manual.

## 1.2 SYSTEM DESCRIPTION

The SR1060 contains a set of six resistance transfer standards in decade steps from 1 ohm to 100 kilohms. With the exception of the 100 kilohm-per-step transfer standard, all of the standards are immersed in oil, providing thermal isolation to minimize the effects of variations in ambient temperature. A Thermometer Well allows convenient measurement of the oil's temperature.

The SR1060 provides the calibration laboratory with accurate standards across a range of 0.1 ohm to 1.2 megohms. These standards can be used in any of three ways, providing different levels of accuracy.

For many applications, the resistor adjustment accuracy is high enough that the resistors can be assumed to have their nominal values. If higher accuracy is required, certified calibration data included with the SR1060 can be used to correct the values. For the highest accuracy, a Resistance Transfer Method can be used to transfer calibration from a high-accuracy reference standard to the entire range spanned by the SR1060. This method provides accuracy at the time of calibration at the ppm accuracy level.

Each resistance transfer standard consists of 12 nominally-equal resistors that are permanently connected in series. Each resistor has two terminals at each end, allowing four-terminal connections to any individual resistor or series-connected group of resistors. The resistors are connected to the terminals using a patented (U.S. Patent No. 3,252,091) four-terminal junction to ensure that the connection to the resistors will allow accurate four-terminal measurements even when the resistors are connected in series or parallel groups.

The SR1060 owes its high accuracy and stability to the precision resistors used. The resistors are wound on specially processed mica cards. The resistors are wound with alloys that have excellent stability, extremely low temperature coefficients, and negligible thermal EMF to copper. Individual resistors with the same nominal value are wound using a technique that yields excellent temperature coefficient and long-term stability matching between resistors.

Each resistor is carefully built and inspected to ensure maximum control of quality, then selected for minimum temperature coefficient and given a rigorous accelerated aging treatment. Each complete resistance transfer standard is given additional stabilization treatment, followed by an extended series of tests to ensure a high standard of quality.

A calibration card is included with the SR1060 which indicates the deviation from nominal for each resistor. In addition, the card gives the cumulative deviation for use when the resistors are used in combination. The calibration data supplied on this card by ESI is directly traceable to standards certified by the National Bureau of Standards (NBS).

An optional Resistance Standard Cart (P/N 58359) is available to support the SR1060 and to allow it to be moved easily. A set of Shorting Bars (Model SB103) are available to provide low impedance parallel and series-parallel connections of resistors within a Resistor Bank. A Parallel Compensation Network (Model PC101) and a Series-Parallel Compensation Network (Model SPC102) are available to use with the Shorting Bars to effectively eliminate connection errors when performing four-terminal measurements on resistors connected in parallel or series-parallel.

### 1.3 RESISTANCE TRANSFER METHOD

The SR1060 allows the accuracy of an independent standard to be transferred throughout the entire 0.1 ohm to 1.2 megohm range using a Resistance Transfer Method. This method produces a 1:10, 1:100, 10:1, and 100:1 transfer of the resistance value of an SR1060 Resistor Bank with negligible loss of accuracy.

The Resistance Transfer Method relies on the fact that a set of ten nominally-equal resistors can be connected in parallel or in series, providing resistance values very close to 1/10 of the nominal and 10 times the nominal. In addition, nine of the resistors can be connected in three parallel sets of three series resistors to provide a resistance value very close to the nominal value. It is easily shown that the deviation from the expected value for the parallel connection is the same as for the series connection. The deviation for the series-parallel connection can be accurately calculated.

As an example of this, the following demonstrates how a 1 ohm high-accuracy standard and the 10 ohm-per-step Transfer Standard can produce accurate 10 and 100 ohm standards. Using a bridge to compare the 1 ohm standard to the Transfer Standard connected in the parallel mode, the deviation between the two can be measured. This (and the known value of the 1 ohm standard) provides a measure of the deviation of the Transfer Standard from nominal. By connecting the Transfer Standard in series-parallel (and by performing the necessary deviation measurements and calculations) a 10 ohm standard is produced. By connecting the Transfer Standard in series, a 100 ohm standard is produced. It will be shown later (in the Theory section) that the value of the deviation of the Transfer Standard in the parallel mode is effectively the same as in the series mode. With one comparison measurement and a simple calculation, the series-parallel value can be determined with comparable accuracy.

In addition to the three connections just discussed, combinations of series and parallel resistors can be made to have values between 1/12 and 12 times the nominal value. Through a sequence of measurements, the deviation of the individual resistors in the Transfer Standard can be measured, providing a measure of the deviation of any of these combinations. In this manner, many accurate values within a 144-to-1 range can be produced with one Transfer Standard.

To ensure accurate parallel and series-parallel operation, several options are available. A pair of shorting bars, Model SB103, is used to connect any number of resistors in parallel or a group of nine resistors in series-parallel. To eliminate the loss of accuracy at lower resistance levels when making four-terminal measurements of ten resistors connected in parallel or nine resistors connected in series-parallel, two Compensation Networks are available: the Model PC101 (parallel) and the Model SPC102 (series-parallel). As a result of the special design of the four-terminal junctions, the Shorting Bars, and the Compensation Networks, the actual values of four-terminal series, parallel, and series-parallel resistor groups will agree with their calculated values to better than  $\pm 1$  ppm, typically about  $\pm 0.1$  ppm.

## SECTION 2

# SPECIFICATIONS

### 2.1 SR1060 SPECIFICATIONS

Nominal Values (per step)	1, 10, and 100 $\Omega$ , 1, 10, and 100 k $\Omega$
Transfer Accuracy 100:1	$\pm(1 \text{ ppm} + 0.1 \text{ u}\Omega)$ at parallel value, using SB103, PC101, and SPC102 as necessary
10:1	$\pm(1 \text{ ppm} + 1 \text{ u}\Omega)$ at series or parallel value, using SB103, PC101, and SPC102 as necessary
Initial Adjustment	$\pm 20$ ppm, matched within 10 ppm
Initial Calibration Certificate	$\pm 10$ ppm, NBS traceable
Calibration Conditions	23 $\pm 1^\circ\text{C}$ , low-power, four-terminal measurement, initial calibration readings are provided
Long-Term Resistance Stability	$\pm 20$ ppm of nominal for six months $\pm 35$ ppm for two years
Temperature Coefficient 1 ohm 10 ohm 100 ohm to 100 kilohm	$\pm 15$ ppm/ $^\circ\text{C}$ , matched within 5 ppm/ $^\circ\text{C}$ $\pm 1$ ppm/ $^\circ\text{C}$ $\pm 5$ ppm/ $^\circ\text{C}$ , matched within 3 ppm/ $^\circ\text{C}$
Power Coefficient (typical) 1 ohm 10 ohm 100 ohm to 100 kilohm	$\pm 0.3$ ppm/mW/resistor $\pm 0.02$ ppm/mW/resistor $\pm 0.1$ ppm/mW/resistor
Maximum Power Rating Single Step 10 in Series	1W/step 5W distributed

Leakage Resistance	$>10^{12} \Omega$ , terminal to case
Breakdown Voltage	1500 V peak to case
Oil Bath	
Oil	
Type	Mineral Oil, USP Light Penco, Sontex 85, white
Insulation Resistance	Typically $10^{14} \Omega$
Quantity	Approximately 3.4 gal (14 l)
Housing	Gasket sealed Fill, drain, and resistance probe ports provided
Dimensions (oil and standards installed)	
Height	120 mm (4.7 in.)
Width	410 mm (16 in.)
Depth	760 mm (30 in.)
Mass	43 kg (Weight 95 lb)
Operating Environment	
Temperature	$22.8 \pm 3.3^{\circ}\text{C}$ ( $73 \pm 6^{\circ}\text{F}$ )
Humidity	20 to 50% relative humidity
Safe Operating Environment	
Temperature	0 to $50^{\circ}\text{C}$ (32 to $126^{\circ}\text{F}$ )
Humidity	15 to 80% relative humidity

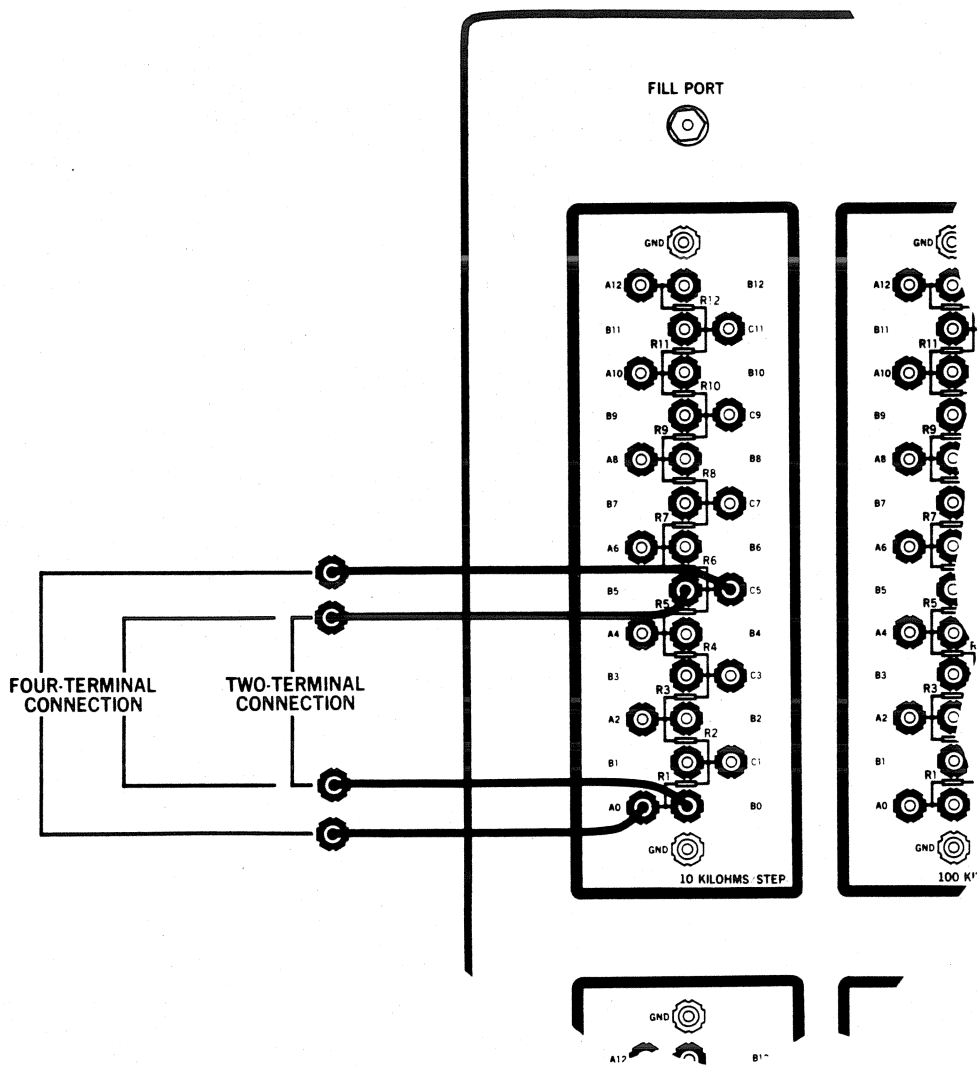

**Figure 3-1. Connecting Five Resistors in Series**

As there is some resistance in the four-terminal junction, consideration must be given to how it will affect the measurement. Figure 3-2 provides an equivalent circuit of  $n$  resistors in series.



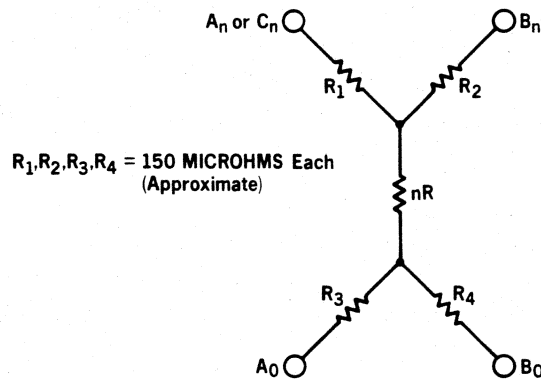

**Figure 3-2. Equivalent Circuit of Series Connection**

As can be seen in Figure 3-2, each of the four lead resistances ( $R_1$  through  $R_4$ ) contributes about 150 microhms. If the effect of these resistances is avoided by a four-terminal measurement, each junction should contribute less than one microhm of resistance.

The bridge lead and connection resistances will be added to the resistance value. As the bridge and connection resistances are typically about 10 milliohms and variable, the internal lead resistance of the Resistor Bank should be negligible.

### 3.1.2 Parallel Connections

Any number of the resistors in a bank may be connected together in parallel by means of the SB103 Shorting Bars. For the 1 and 10 ohm-per-step Resistor Banks, the paralleling leads and contact resistance may cause significant errors.

When connecting ten resistors in parallel, these errors can be essentially eliminated by the use of the PC101 Parallel Compensation Network. Refer to Figure 3-3 for an illustration of a four-terminal parallel connection using the SB103 and the PC101.

**NOTE:** Throughout this section, the terminals on the Equivalent Circuits are labeled 1 through 4. These numbers correspond to the terminal numbers on an ESI Model 240C Kelvin Ratio Bridge. In general terms for a Kelvin bridge, terminal 1 connects to the Generator, 2 connects to the Main Bridge Arms, 3 connects to the Yoke Arms, and 4 connects to the Yoke. When using an active arm bridge (such as an ESI Model 1700 or an ESI Model SP2522B) 1 connects to High Drive (current), 2 connects to High Sense (potential), 3 connects to Low Sense, and 4 connects to Low Drive.

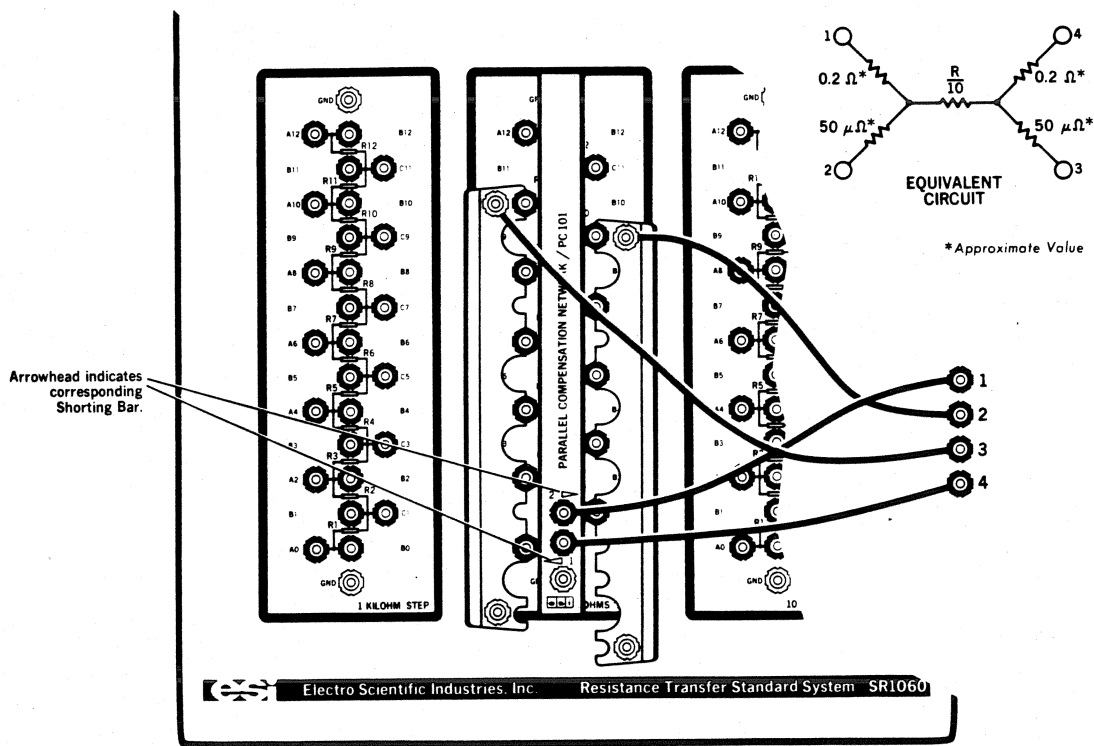

Figure 3-3. Four-Terminal Parallel Connection with Compensation Network

When the Parallel Compensation Network is used, the resistance in series with it is considerably higher than that in series with the Shorting Bars. Care should be taken when connecting this arrangement to a measuring device to ensure that the effect of this resistance is minimized. The labels in Figure 3-3 indicate the proper connection order.

A simplified four-terminal parallel connection of any number of resistors can be made using only the Shorting Bars as shown in Figure 3-4. This places a small connection resistance in series with the paralleled resistance. However, this value should be negligible for the Resistor Banks with nominal values of 1 kilohm-per-step and higher. If accurate measurements are required on the lower valued Resistor Banks, the PC101 Compensation Network should be used.

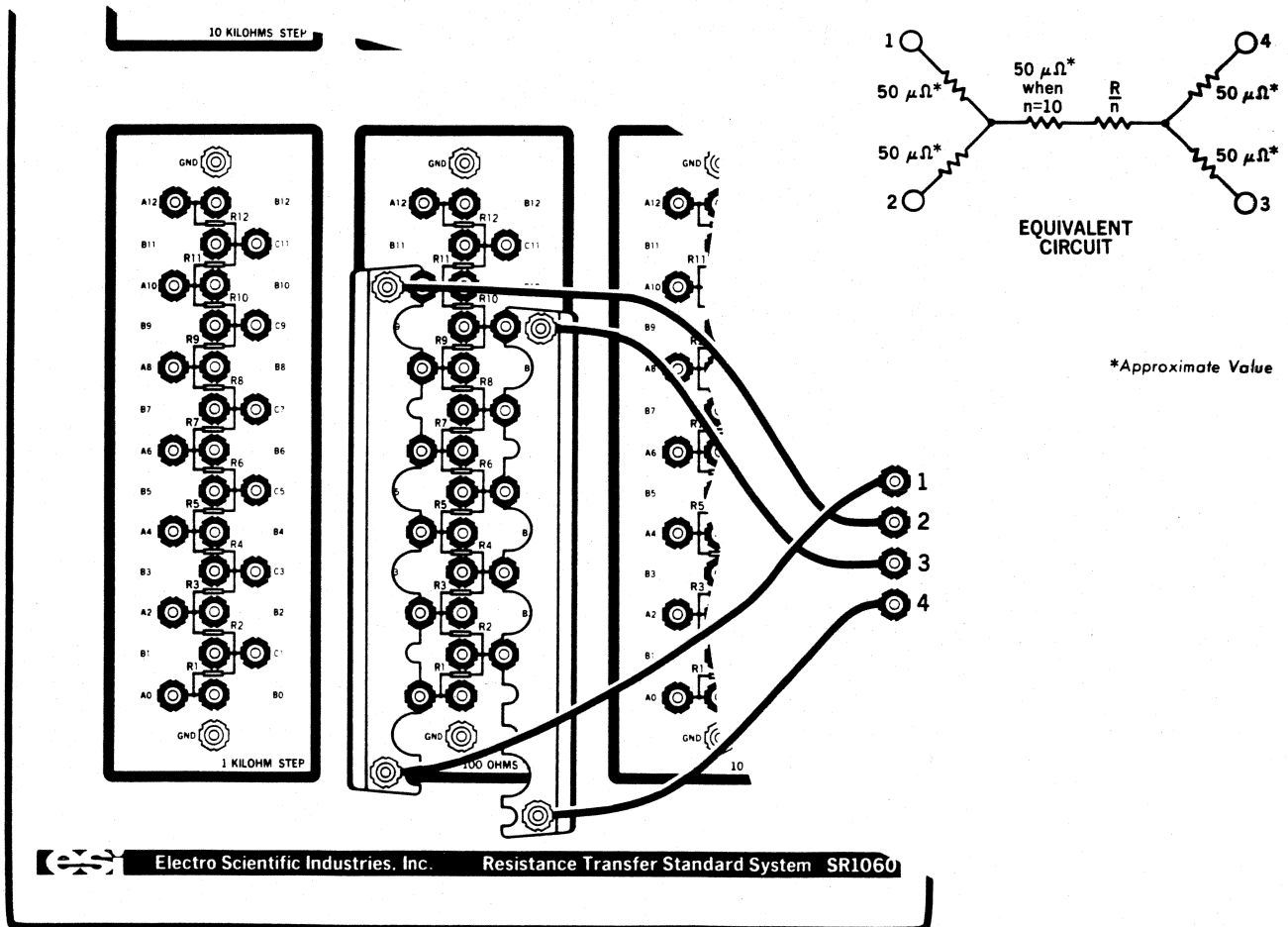

Figure 3-4. Four-Terminal Parallel Connection with Shorting Bars

For calibration of another voltage divider, an additional accessory can be used to compensate for lead and contact resistance. An ESI Model LC875 Lead Compensator or equivalent is recommended. The Lead Compensator is connected between terminals A0, A10, and the input of the divider to be calibrated, as shown in Figure 3-9. With the detector connected between B0 and the minimum end of the divider to be calibrated, the Lead Compensator is adjusted for a detector null. With the detector connected between B10 and the maximum end of the divider, the Lead Compensator is adjusted for a detector null. The divider may then be accurately compared to the SR1060 Resistor Bank at integral multiples of one tenth the full scale voltage.

For calibrating other than the first decade of a Kelvin-Varley voltage divider it is necessary to connect the generator to the input of the decade under calibration. This will normally require making an internal connection to the divider, as shown in Figure 3-9. This method gives a complete, high accuracy calibration of the whole Kelvin-Varley divider, including all lead and switch resistances.

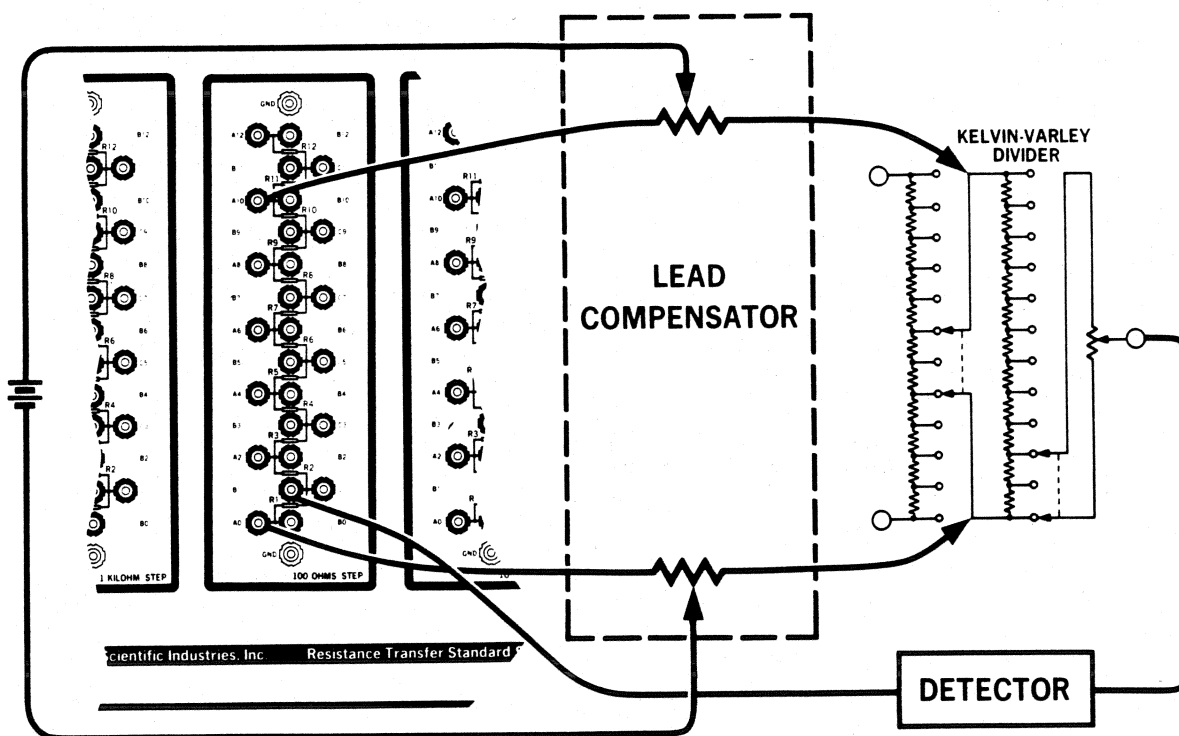

Figure 3-9. Voltage Divider Connection with Lead Compensator

### 3.2 THERMOMETER WELL

In the center of the Fill Port is a Thermometer Well, as shown in Figure 3-10. This is provided to allow the temperature of the Silicone Oil to be easily measured. The well has been designed to accept an ASTM 17C-type thermometer. If a small quantity of water is kept in the well, it will provide better thermal contact between the thermometer and well.

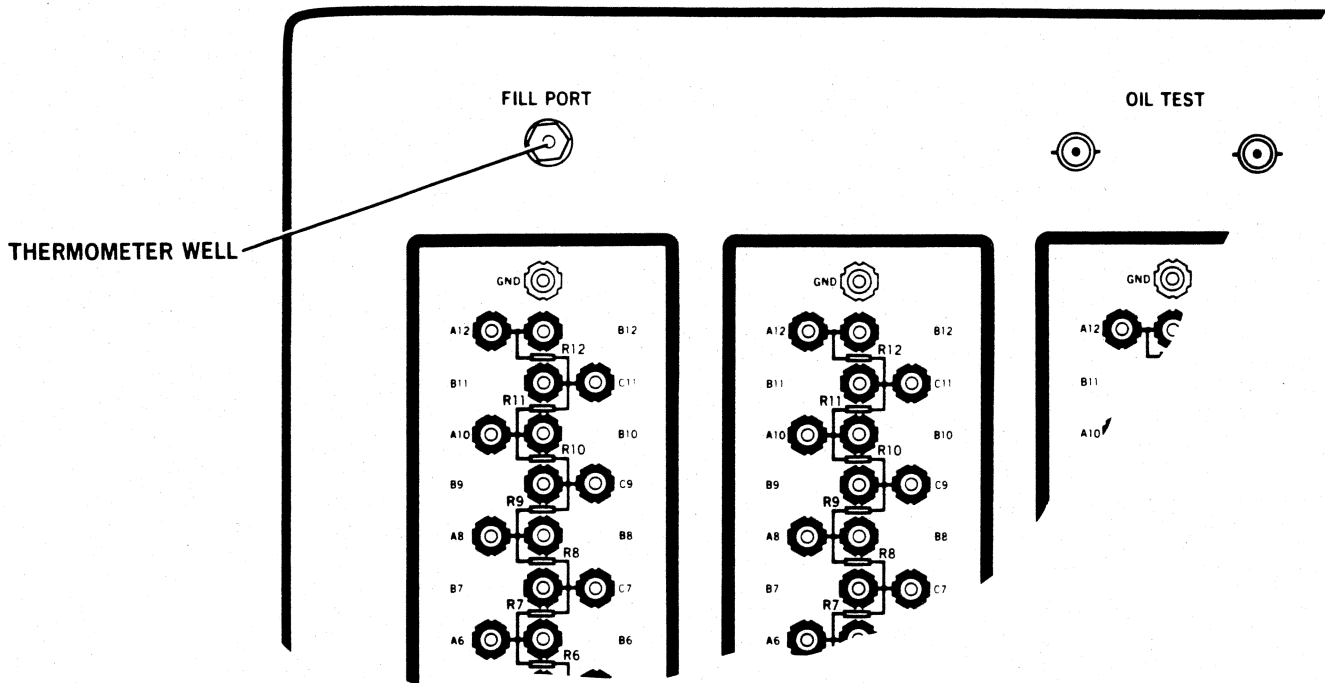

Figure 3-10. Location of Thermometer Well

### 3.3 HIGH ACCURACY CALIBRATION TRANSFER

The name Resistance Transfer Standard refers to a Resistor Bank in the SR1060 that can be measured at one resistance value and used with nearly equal accuracy at a different resistance value. In a sequence of measurements using such transfers to trace calibration from a reference standard to an unknown resistor, neither the absolute value nor the long-term stability of the resistors in the SR1060 nor the bridge used for the comparisons has any significant effect on the measurement accuracy. The burden of calibration accuracy and long-term stability is placed on the reference standard alone; the concern with the rest of the system need be only with its short-term stability during the period of a few minutes required to complete the measurements. With careful operating techniques in a normal laboratory environment, each step in such a series of measurements can be accurate to one or two ppm.

In making such a chain of measurements, an advantage of using a Resistance Transfer Standard is that an accurate 100:1 transfer in resistance value can be made by only changing the connections, thus minimizing the accumulation of errors. For example, the limits of error in measuring a 1 ohm resistor might be assumed as follows:

Certified accuracy of 10 kilohm standard	1 ppm
Comparison of 10 kilohm standard with 1 kilohm-per-step bank in SR1060 (connected for 10 kilohms)	2 ppm
Comparison of 1 kilohm-per-step bank with 10 ohm-per-step bank (both connected for 100 ohms)	2 ppm
Comparison of 10 ohm-per-step bank (connected for 1 ohm) with unknown 1-ohm resistor	2 ppm
Sum of Error Limits	<hr/> 7 ppm
Square Root of the Sum of the Squares	3.6 ppm

**NOTE:** If the individual steps are independent and normally distributed, the square root of the sum of squares should be used as the total uncertainty.

A similar procedure can be used to transfer (in two steps) from a 1 ohm standard to 10 kilohms and (with 2 more steps) to 1 megohm, or (with 2 more steps) to 100 megohms using the ESI SR1050 High Resistance Transfer Standard.

For highest accuracy, such a transfer procedure may be repeated each time a measurement of an unknown resistor is made. If, during such measurements, a record is kept of the calibration of each Resistor Bank in the SR1060 that is used, a quantity of data will soon be accumulated with a minimum of effort. This data will indicate the stability of the SR1060 and/or the variations in calibration resulting from changes in ambient conditions, operators, or techniques. It can serve to indicate the actual accuracy of the data on the calibration chart under the laboratory conditions prevailing and it will indicate when it is time to replace the calibration chart and supply dependable data for a new chart.

### 3.3.1 Comparing Nominally Equal Values

The comparison of like resistance values can be made independent of the absolute accuracy and long-term stability of the comparison bridge by using either an interchange or a substitution method. A direct-reading double ratio set such as ESI Model 240C Kelvin Ratio Bridge or ESI Model 120 Direct Reading Double Ratio Set should be used for calibration transfer with the SR1060. These instruments can be used to make four-terminal comparison measurements with resolution and short-term stability between 0.1 ppm and 1 ppm.

#### 3.3.1.1 Interchange Method

**NOTE:** If the first unknown resistor used in the following example can be adjusted (as with the ESI RS925D), the calculation can be simplified. This resistor should be adjusted to balance the bridge in the first STEP, making  $D_2$  equal to 0. The deviation will then be  $D_1/2$ .

- STEP 1. With the first unknown resistor connected to the unknown terminals of the bridge and the second unknown resistor connected to the standard terminals, balance the bridge, and determine the (uncalibrated) deviation of the first unknown from the second unknown. Call this reading  $D_2$ .
- STEP 2. Interchange the two resistors (that is, connect the second unknown resistor to the unknown terminals and connect the first unknown resistor to the standard terminals), balance the bridge, and determine the (uncalibrated) deviation of the second unknown from the first unknown. Call this reading  $D_1$ .
- STEP 3. Calculate  $(D_1 - D_2)/2$ , the calibrated deviation of the second resistor from the first resistor. If the deviation from nominal of the first resistor is known, add it to the deviation just calculated. This produces the deviation of the second resistor from nominal value.



### 3.3.1.2 Substitution Method

To measure the difference between two unknown resistors by the substitution method, connect a working standard resistor of the required nominal value to the standard terminals of the bridge and make two measurements. The first measurement is to be made with the first unknown resistor connected to the unknown terminals. The second measurement is to be made with the second unknown resistor connected to the unknown terminals. The difference between these two readings will be the difference between the values of the two resistors.

The substitution method is particularly convenient when the deviation of the first resistor is known and both the working standard and the bridge ratio can be adjusted to make the bridge deviation dial read deviation from nominal value directly. When the first resistor is connected to the unknown terminals, the deviation dial is adjusted to its known deviation from nominal value and the working standard is used to balance the bridge. When the first resistor is disconnected and the second (unknown) resistor is connected to the unknown terminals, the deviation dial at balance will indicate directly the deviation of the second (unknown) resistor from nominal value.

In a sequence of calibration transfer measurements in which the second (unknown) resistance in one comparison and the first (known) resistance in the next consist of the same group of SR1060 resistors differently connected, the deviation reading in the first comparison becomes the initial deviation setting for the next measurement. Thus the dial setting serves as a mechanical memory and indicates the actual deviation value through the whole series of measurements, including the final reading on the second (unknown) resistor.

### 3.3.2 Primary Resistance Standards

It is necessary to begin any chain of measurements with a primary standard resistor with a value that is accurately known and highly stable. The ESI Model SR104 is such a resistor and is recommended for this purpose. The use of this resistor is simple and does not require a regulated-temperature oil bath, high-accuracy thermometers, or other such equipment. The SR104 has an internal oil bath, a low temperature coefficient, and a sealed-in temperature probe. The value of the SR104 is 10 kilohms  $\pm 5$  ppm. The SR104 can be calibrated by the NBS to a certified accuracy of  $\pm 1$  ppm.

Another commonly used primary resistance standard is the Thomas-pattern 1 ohm resistor, well known for its long-term stability. The following will aid in making accurate measurements at the 1 ohm level:

STEP 1. Operate the Thomas-pattern resistor in oil to minimize its temperature rise with power dissipation and to allow accurate measurement of the resistor temperature. If accurate temperature coefficient data is available for the resistor (alpha, which is about  $+5$  ppm/ $^{\circ}\text{C}$ , and beta terms), a small pot of unstirred oil at room temperature is quite adequate. Measure the oil temperature to an accuracy of  $\pm 0.2^{\circ}\text{C}$  and calculate the value of the resistor at this temperature. Since heating by the resistor may raise the oil temperature enough to significantly affect the resistance, the temperature should be measured again when the bridge is balanced.

STEP 2. To avoid internal heating of the standard and the SR1060, use reduced input power to the bridge for the initial balance adjustment, increase power to approximately 1/2 watt (2/3 ampere through standard and unknown) for only a few seconds, make the final, accurate balance adjustment, and read the oil temperature. The resistance of both the Thomas-pattern resistor and the SR1060 will typically remain constant within 1 ppm for approximately 10 seconds at this power level.

STEP 3. When using the 1 ohm-per-step SR1060 Resistor Bank, complete its comparison with the reference standard and its use in calibrating higher value Resistor Banks in as short a time as possible to keep all the measurements at as nearly the same temperature as possible. The exact temperature of an SR1060 in calibration transfer is unimportant, but its temperature must remain sufficiently constant throughout the procedure. This is particularly important with the 1 ohm resistors, since they have higher temperature coefficient differences, about 5 ppm/°C, than the higher value resistors.

In changing the connections to the SR1060, avoid unnecessary handling to minimize temperature changes and differential thermal voltages.

### 3.3.3 Calibration Transfer Between SR1060 Transfer Standards

In calibration transfer measurements, the three most commonly used connection configurations for the Resistor Banks are: ten resistors in parallel, nine resistors in series-parallel, and ten resistors in series. These connections yield resistance values of 0.1, 1, and 10 times the individual resistor value. It is desirable to use one of these groups of resistors in preference to any single resistor, in order to minimize temperature rise with internal heating and to take advantage of averaging of temperature coefficients of the resistors.

The basic absolute resistance calibration of a Resistor Bank in the SR1060 is accomplished by accurately measuring any one of these three connection configurations. Once the reference standard (or a previously calibrated SR1060) has been used to calibrate one of these three configurations for a Resistor Bank, the values for the other configurations are obtained by a simple comparison measurement and calculation.

For 1 ppm accuracy in calibrating or using the ten resistor parallel configuration with the 1, 10, and 100 ohm-per step Resistor Banks, or using the nine resistor series-parallel configurations with the 1 and 10 ohm-per-step Resistor Banks, the PC101 and SPC102 Compensation Networks should be used. The simplified four-terminal connection using the SB103 Shorting Bars alone is adequate for the 1 kilohm-per-step and higher value Resistor Banks (refer to Section 3.1.3).

The recommended sequence for calibration transfer to the various SR1060 Resistor Banks is listed in Table 3-1.

**Table 3-1. Recommended Calibration Transfer Sequence**

SR1060 per-step Resistor Value	Connection	Number of Resistors	Net Value	Compared to
100 kilohm	Parallel	10	10 kilohm	10 kilohm
10 kilohm	Series-Parallel	9	10 kilohm	Primary Standard (ESI SR104)
1 kilohm	Series	10	10 kilohm	
100 ohm	Series	10	1 kilohm	1 kilohm-per-step SR1060 Resistor Bank in Series-Parallel
10 ohm	Series	10	100 ohm	1 kilohm-per-step SR1060 Resistor Bank in Parallel
1 ohm	Series	10	10 ohm	10 ohm-per-step SR1060 Resistor Bank in Series-Parallel

### 3.3.4 Calibration Transfer Between Principal Resistor Configurations

The majority of calibration transfer applications require the use of only the three principal resistance configurations for the SR1060 Resistor Banks. For these measurements, the individual resistors need never be calibrated. This is the key to both the high accuracy and the extreme simplicity of this transfer technique.

Fortunately, it can be shown that nominally equal resistors connected in configurations which use the same group of resistors and distribute the power equally among them have the same deviation from the nominal values for the configurations. This deviation is equal (to one part in  $10^9$  for the resistor matching used in the SR1060) to the average of the deviations of the individual resistors in the group from their nominal value.

When a particular group of nominally equal resistors, all dissipating the same power, is calibrated in one configuration and exactly the same group is used in another configuration, still maintaining equal power dissipation at the new resistance value, no further measurements are necessary and no calculations are required for determining the calibrated value at the new level. Ten resistors in series will therefore have almost exactly 100 times the resistance of the same ten resistors in parallel. Similarly, nine resistors in series-parallel, giving the same nominal resistance as the individual resistors, will have almost exactly nine times their resistance in parallel, or almost exactly one ninth of their resistance in series. In each case, the deviation will be almost exactly the average of the deviations of the individual resistors. Proof of these statements can be found in Theory, Section 4 of this manual.

To transfer calibration between the ten resistor group and the nine resistor group, the difference of the unused tenth resistor from the nine-resistor series-parallel configuration must be measured\*. This measured difference and the calibrated deviation of any of the three configurations can be used to calculate the deviation of the other two configurations. The difference between the two (parallel and series are equal) average deviations is given by:

$$d_{sp}^9 - d_{cu}^{10} = 0.1 (d_{sp}^9 - d_{10})$$

Where:

$d_{sp}^9$  is the (measured or calculated) deviation of the nine resistor series-parallel group from nominal (this deviation is equal to the average of the deviations of the nine resistors)

$d_{cu}^{10}$  is the (measured or calculated) deviation of the ten resistor series or parallel group from nominal (this deviation is equal to the average of the deviations of the ten resistors)

$d_{sp}^9 - d_{10}$  is the measured difference between the nine resistor series-parallel configuration and the tenth resistor (whose deviation is  $d_{10}$ )

Notice that the resistance value of the tenth resistor need never be known, only its difference from the resistance value of the series-parallel circuit. This difference can be easily measured by the substitution method. As this difference is divided by 10 when it is used, its accuracy is somewhat less important.

---

\*For transfer standard values requiring the use of the Compensation Networks, this measurement must be made by the substitution method rather than the interchange method, since the network must be removed to connect to the tenth resistor for measurement.

### 3.3.5 Calibration Transfer to Individual Resistors

There are two methods which can be used to calibrate the 12 resistors in one SR1060 Resistor Bank.

The first method involves making individual measurements with a bridge calibrated to the same nominal value as the individual resistors. With this method, the measured deviations are the best known deviations from nominal for each resistor. Using this method, the bridge can be calibrated to the nominal value of the resistors in either of two methods. The simpler method involves calibrating the bridge using a calibrated standard with the same nominal value as the resistors. The more complicated method involves calibrating the bridge using a calibrated standard whose nominal value is ten times or one tenth of the nominal value of the individual resistors. The appropriate Resistor Bank is calibrated (in series or parallel) at the same value as the standard. By performing two measurements (R10 and the Resistor Bank in series-parallel) and making a simple calculation, the bridge can be calibrated at the nominal value of the resistors. Each of the twelve resistors can then be measured directly.

The second method involves measuring the twelve resistors with a bridge that is uncalibrated. The individual deviations are recorded, noting that they are deviations from some unknown value. The series or parallel value of the resistors is then compared to a calibrated standard, with the deviation being used to correct the original twelve deviations.

Both of these procedures are listed in a step-by-step manner in Calibration Procedure, Section 3.4.1.



### 3.3.6 Calibration of an SR1060 as a Ten-Step Divider

Since ratio measurements do not depend upon any absolute resistance standard, no reference standard of resistance is required to calibrate an SR1060 as a divider. As is shown in Theory, Section 4, an excellent approximation of the deviation,  $L$ , of a decade divider is given by:

$$L = (n/10) * (d_{cu}^n - d_{av})$$

Where:

$d_{cu}^n = (\sum_{i=1}^n d_i)/n$  is the cumulative deviation of the first  $n$  resistors

$d_{av}$  is the average deviation of the ten resistors

Since this equation requires the measurement (or calculation) of the difference between the cumulative deviation and the average deviation, and not the actual values of these two quantities, an uncalibrated bridge can be used. Any deviation caused by the calibration error of the bridge will be cancelled by the subtraction.

If the deviations of the individual resistors are known (as measured in the preceding section), these deviations can be used to calculate the linearity deviation directly.

Calculation of the linearity deviation by both methods is included in Calibration Procedure, Section 3.4.1.

### 3.4 CALIBRATION CARD

The SR1060 is supplied with a calibration card that gives resistance calibration data for each bank of resistors, in terms of their deviation from nominal value, expressed in parts per million. These values are based on four-terminal measurements; two-terminal measurements must be corrected for the connection resistances, as discussed in CONNECTIONS, Section 3.1. An example of a calibration card is shown in Figure 3-11.

**MODEL SR1060**
**Resistance Transfer Standard System**

TRACEABLE TO THE  
U.S. NATIONAL BUREAU OF STANDARDS

OIL RESISTIVITY \_\_\_\_\_

READING \_\_\_\_\_

DATE \_\_\_\_\_

**100 KILOHMS/STEP  
DEVIATION FROM NOMINAL**

	Individual (ppm)	Cumulative (ppm)
R1		
R2		
R3		
R4		
R5		
R6		
R7		
R8		
R9		
R10		
R11		
R12		

INSPECTOR \_\_\_\_\_

DATE \_\_\_\_\_

TEMPERATURE \_\_\_\_\_

SERIAL NUMBER \_\_\_\_\_

**10 KILOHMS/STEP  
DEVIATION FROM NOMINAL**

	Individual (ppm)	Cumulative (ppm)
R1		
R2		
R3		
R4		
R5		
R6		
R7		
R8		
R9		
R10		
R11		
R12		

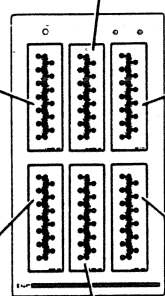

**1 OHM/STEP  
DEVIATION FROM NOMINAL**

	Individual (ppm)	Cumulative (ppm)
R1		
R2		
R3		
R4		
R5		
R6		
R7		
R8		
R9		
R10		
R11		
R12		

**1 KILOHM/STEP  
DEVIATION FROM NOMINAL**

	Individual (ppm)	Cumulative (ppm)
R1		
R2		
R3		
R4		
R5		
R6		
R7		
R8		
R9		
R10		
R11		
R12		

**100 OHMS/STEP  
DEVIATION FROM NOMINAL**

	Individual (ppm)	Cumulative (ppm)
R1		
R2		
R3		
R4		
R5		
R6		
R7		
R8		
R9		
R10		
R11		
R12		

**10 OHMS/STEP  
DEVIATION FROM NOMINAL**

	Individual (ppm)	Cumulative (ppm)
R1		
R2		
R3		
R4		
R5		
R6		
R7		
R8		
R9		
R10		
R11		
R12		

MAXIMUM POWER 1 WATT PER RESISTOR OR  
5 WATTS TOTAL

Electro Scientific Industries, Inc.  
13900 N.W. Science Park Drive • Portland, Oregon 97229 • Telephone: (503) 641-4141 • Telex 4742064

**Figure 3-11. Calibration Card**

3 - 24

e|s|i SR1060 Resistance Transfer Standard System 8/86

The first column gives the measured deviation of each resistor from its nominal value. The second column gives the cumulative average of the deviation figures in the first column, rounded to the same number of significant figures as the first column. For example, to the right of R7, the figure in the first column is the measured deviation of R7 from nominal, while the figure in the second column is the calculated average deviation of resistors R1 through R7.

The cumulative average deviation in the second column calibrates any series, parallel, or series-parallel connection of the corresponding group of resistors in which the power divides equally among all the resistors in the group. For example, the first nine resistors in a one ohm-per-step box can be connected in series for a nominal value of nine ohms, in parallel for one-ninth of an ohm, or in series-parallel for one ohm; the actual value of each of these three alternate connections will effectively be the same number of parts per million, the cumulative deviation shown in column 2 opposite R9, away from the nominal value for that connection.

### 3.4.1 Calibration Procedure

The following procedures can be used to verify the calibration readings on the Calibration Card or to supply data for a new card. These procedures should be performed only by those who have the necessary facilities. Calibration should be performed in a laboratory environment with a resistance measuring system of the required sensitivity and accuracy, and with a primary resistance standard for which the resistance is adequately known.

**NOTE:** The signs (positive or negative) of the values used in the equations in the following procedures are significant and must not be ignored.

**NOTE:** Both of the following procedures make reference to balancing the bridge. It is assumed that the operator will follow the appropriate procedure of zeroing the meter, reversing the generator polarity to check for thermal voltages, and performing lead and yoke adjustments whenever balancing is required.

#### 3.4.1.1 First Method

The first method involves calibration of the bridge at the nominal value of the resistors. The deviation of each of the individual resistors is then measured directly.

**NOTE:** If a resistance standard is available with a nominal value equal to the nominal value of the resistors to be calibrated and an ESI Model 242 Resistance Measuring System is used, several STEPS can be eliminated. Connect the standard to the UNKNOWN terminals of the bridge and set the DEVIATION dial on the bridge to the known deviation of the standard. Balance the bridge by adjusting the resistance standard connected to the STANDARD terminals of the bridge. The bridge is now calibrated. Make a copy of the Calibration Chart found in Figure 3-13 and proceed to STEP 12. An example of a completed Calibration Chart is found as Figure 3-12.

- STEP 1. Make a copy of the Calibration Chart found in Figure 3-13. It will be used to keep track of the intermediate results and assist in the calculations. An example of a completed Calibration Chart and part of a Calibration Card is found as Figure 3-12.
- STEP 2. Select a calibrated standard resistor with a nominal value equal to ten times or one tenth of the nominal value of the individual resistors of the SR1060 Resistor Bank to be calibrated. Connect this standard resistor to the UNKNOWN terminals on the bridge.
- STEP 3. Set the DEVIATION dial of the bridge to the known deviation of the standard and balance the bridge by adjusting the resistance standard.
- STEP 4. Connect the Resistor Bank in series or parallel to have the same nominal value as the standard resistor used in STEP 1. Connect this Resistor Bank to the UNKNOWN terminals on the bridge.
- STEP 5. Balance the bridge with the DEVIATION dial. Read and record the setting as  $d_{av}^{10}$  on the Calibration Chart.
- STEP 6. Set the DEVIATION dial to 0. Connect the SR1060 R10 to the UNKNOWN terminals on the bridge.
- STEP 7. Balance the bridge with the resistance standard. This calibrates the bridge to the (unknown) value of R10.
- STEP 8. Connect R1 through R9 of the SR1060 in series-parallel, using the Shorting Bars and (if the nominal resistor value is 1, 10, or 100 ohms) the SPC102 Compensation Network. Connect the Resistor Bank to the UNKNOWN terminals on the bridge.

STEP 9. Balance the bridge with the DEVIATION dial. Read and record the setting as  $d_D$  on the Calibration Chart. This is the difference of the value of the series-parallel network from the value of  $R_{10}$ .

STEP 10. Calculate  $d_{sp}$  using the following:

$$d_{sp} = d_{av}^{10} + 0.1 * d_D$$

STEP 11. Set the DEVIATION dial to  $d_{sp}$ . Leaving the series-parallel network connected, balance the bridge using the resistance standard. The bridge is now calibrated at the nominal value of the individual resistors.

STEP 12. Connect each resistor ( $R_1$  through  $R_{12}$ ) in turn, to the UNKNOWN terminals of the bridge. Balance the bridge using the DEVIATION dial to measure the deviation of the resistor connected to the UNKNOWN terminals of the bridge. Record this deviation for each resistor in column B (Corrected Individual Deviations) of the Calibration Chart. Column A (Measured Individual Deviations) of the Calibration Chart is not used in this procedure.

STEP 13. Round the individual deviations to the nearest ppm and record them in the first column of the Calibration Card.

STEP 14. Sum the individual deviations from the first to each of the subsequent deviations and record these sums in column C (Cumulative Sum) of the Calibration Chart.

STEP 15. Divide each cumulative sum by the number of resistors involved in the sum and record the results in column D (Cumulative Average) of the Calibration Chart.

STEP 16. Round the cumulative averages to the nearest ppm and record them in the second column of the Calibration Card.

STEP 17. Subtract the tenth cumulative average from each of the first nine cumulative averages in turn, multiply each result by the number of resistors involved in the cumulative average, and divide by 10. Round the results to one decimal place and enter the results in column E (Linearity Deviation) of the Calibration Chart. This is the linearity deviation for each of the first nine steps when the Resistor Bank is used as a decade divider. For example, the fifth linearity deviation is calculated as:

$$(1.2 - 1.5) * 5/10 = -0.15$$

This would be rounded to -0.2 when entered in the Chart.

	A	B	C	D	E	PART OF CALIBRATION CARD	
	Measured Individual Deviation	Corrected Individual Deviation	Cumulative Sum	Cumulative Average	Linearity Deviation	100 OHMS/STEP DEVIATION FROM NOMINAL	
						Individual (ppm)	Cumulative (ppm)
R1	+3.6	+2.1	+2.1	+2.1	+0.1	+2	+2
R2	+5.7	+4.2	+6.3	+3.2	+0.3	+4	+3
R3	+0.3	-1.2	+5.1	+1.7	+0.1	-1	+2
R4	+5.3	+3.8	+8.9	+2.2	+0.3	+4	+2
R5	-1.6	-3.1	+5.8	+1.2	-0.2	-3	+1
R6	+4.9	+3.4	+9.2	+1.5	0.0	+3	+2
R7	+4.5	+3.0	+12.2	+1.7	+0.1	+3	+2
R8	-3.2	-4.7	+7.5	+0.9	+0.5	-5	+1
R9	+4.0	+2.5	+10.0	+1.1	+0.4	+2	+1
R10	+6.6	+5.1	+15.1	+1.5		+5	+2
R11	+3.2	+1.7	+16.8	+1.5		+2	+2
R12	-2.7	-4.2	+12.6	+1.0		-4	+1

Figure 3-12. Completed Calibration Chart

### 3.4.1.2 Second Method

The second method uses an uncalibrated bridge to perform the initial measurements. The deviation between the calculated value of resistance in either the series or parallel connection is measured relative to a known standard. This deviation is applied to the original uncalibrated measurements to correct for the bridge error.

- STEP 1. Make a copy of the Calibration Chart found in Figure 3-13. It will be used to keep track of the intermediate results and assist in the calculations. An example of a completed Calibration Chart is found as Figure 3-12.
- STEP 2. Measure the resistance value of each of the 12 resistors in the SR1060 Resistor Bank that is to be calibrated. The bridge does not need to be calibrated at this point. Record the deviation (in ppm) from nominal of each resistor in column A (Measured Individual Deviations) of the Calibration Chart.
- STEP 3. Using the formula listed on the Calibration Chart, calculate  $D_{av}$ , the uncalibrated average of the deviation of the first ten resistors. Record this on the Calibration Chart.
- STEP 4. Select a calibrated standard resistor with a nominal value equal to ten times or one tenth of the nominal value of the individual resistors of the Resistor Bank. Connect this standard resistor to the UNKNOWN terminals on the bridge.
- STEP 5. Set the DEVIATION dial of the bridge to the known deviation of the standard resistor. Balance the bridge using the resistance standard.
- STEP 6. Connect the Resistor Bank in series or parallel to have the same nominal value as the standard resistor. Connect the Resistor Bank to the UNKNOWN terminals on the bridge.



- STEP 7. Measure the deviation (in ppm) from nominal for the Resistor Bank. Record this as  $d_{av}$  on the Calibration Chart.
- STEP 8. Calculate the correction value by subtracting  $D_{av}$  from  $d_{av}$ . Add this correction value to each number in column A of the Calibration Chart and record the results in column B (Corrected Individual Deviations).
- STEP 9. Round the individual deviations (in column B) to the nearest ppm and record them in the first column of the Calibration Card.
- STEP 10. Sum the individual deviations (in column B) from the first to each of the deviations and record these sums in column C (Cumulative Sum) of the Calibration Chart.
- STEP 11. Divide each cumulative sum by the number of resistors involved in the sum and record the results in column D (Cumulative Average) of the Calibration Chart.
- STEP 12. Round the cumulative averages to the nearest ppm and record them in the second column of the Calibration Card.
- STEP 13. Subtract the tenth cumulative average from each of the first nine cumulative averages, multiply each result by the number of resistors involved in the cumulative average, and divide by 10. Round the results to one decimal place and enter the results in column E (Linearity Deviation) of the Calibration Chart. This is the linearity deviation for each of the first nine steps when the Resistor Bank is used as a decade divider. For example, the fifth linearity deviation is calculated as:

$$(1.2 - 1.5) * 5/10 = -0.15$$

This would be rounded to -0.2 when entered in the Chart.

$$d_{10}^{av} = \underline{\hspace{2cm}} \quad d_D = \underline{\hspace{2cm}}$$

$$d_{sp} = d_{10}^{av} + 0.1 \times d_D = \underline{\hspace{2cm}}$$

	A	B	C	D	E
	Measured Individual Deviation	Corrected Individual Deviation	Cumulative Sum	Cumulative Average	Linearity Deviation
R1					
R2					
R3					
R4					
R5					
R6					
R7					
R8					
R9					
R10					
R11					
R12					

$$D_{av} = 0.1 (d_1 + d_2 + \dots + d_{10}) = \underline{\hspace{2cm}}$$

$$d_{av} = \underline{\hspace{2cm}}$$

$$\text{Correction Factor} = d_{av} - D_{av} = \underline{\hspace{2cm}}$$

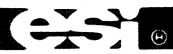

Electro Scientific Industries, Inc.  
 13900 N.W. Science Park Drive • Portland, Oregon 97229 • Telephone (503) 641-4141 • Telex 4742064

**Figure 3-13. Calibration Chart**

## SECTION 4 THEORY

### 4.1 JUNCTION RESISTANCE

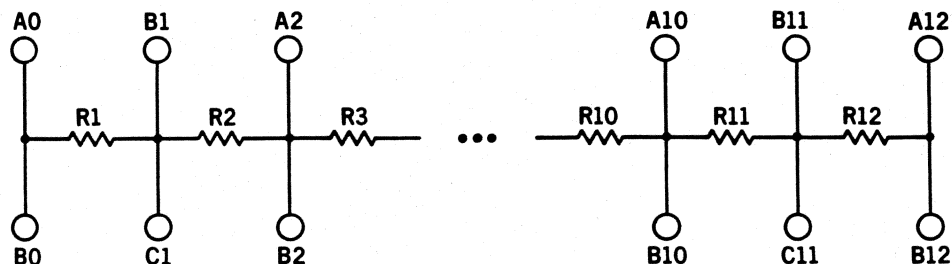
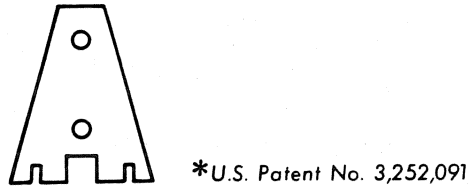

Figure 4-1. Resistor Configuration

The series configuration of a Resistor Bank in the SR1060 Transfer Standard is shown in Figure 4-1. The four-terminal resistors can be measured individually or in any series combination. For the measured series resistance to be equal to the sum of the individual resistor measurements, the junctions must have zero four-terminal resistance. This junction transresistance is zero if a current source connected to each pair of the four-junction terminals produces zero voltage difference between the other two terminals.

The junction design used in the SR1060 (Figure 4-2)\* has a theoretical transresistance of zero. For this to be true, if a current source is connected to any two terminals of this junction, the other two terminals will always be on an equipotential line. In practice, as a result of manufacturing tolerances, the junctions may have some transresistance. This can be measured.



**Figure 4-2. Four-Terminal Junction**

The junction resistance of interest is the difference between a four-terminal measurement of two resistors in series and the sum of the four-terminal measurements of the same two resistors. The junction transresistance can be determined to find if it is negligible relative to the resistor value. Two resistance measurements must be made, as shown in Figure 4-3. These measurements can be determined to sufficient accuracy by the voltmeter-ammeter method.

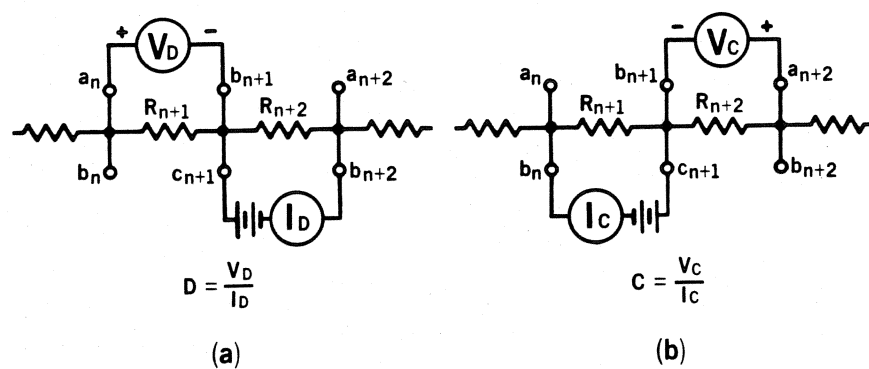

**Figure 4-3. Measuring Transresistance**

The transresistances C and D may be either positive or negative. The circuits shown will indicate the correct polarity. If a bridge is used to measure the transresistance, it may be necessary to reverse one set of leads since the bridge cannot measure negative resistance. The algebraic sum of the resistances C and D may also be either positive or negative and can either increase or decrease the series measurement relative to the sum of the individual measurements. The sum of C and D should be negligible relative to the value of the resistors involved. For example, it should be less than a microhm for the one ohm-per-step Resistor Bank of the SR1060. The ESI Model 801B Generator Detector can be used to make the transresistance measurements. With the generator RANGE set to one ohm and the POWER LIMIT set to 1000 mW, it becomes a source of one ampere current to a one ohm resistor. With the detector on the 1 microvolt range, the junctions of the one ohm-per-step Resistor Bank can be checked down to the 0.1 ppm level since the meter will read one ppm full scale. Table 4-1 lists the Generator settings and the transresistance sensitivity for the other SR1060 Resistor Banks when using the Model 801B. The Generator POWER LIMIT should be set to 1000mW in all cases.

**Table 4-1. Model 801B Settings for Transresistance Measurement**

SR1060 Resistance	Generator RANGE ( $\Omega$ )	Measurement Current (A)	$\mu\Omega/\mu V$	ppm/ $\mu V$
1	1	1	1.00	1.00
10	10	0.3	3.33	0.33
100	100	0.1	10.00	0.10
1000	1000	0.03	33.33	0.03
10000	10000	0.01	100.00	0.01
100000	100000	0.003	333.33	0.003

## 4.2 INSULATION RESISTANCE

Each terminal has some leakage resistance to the case. When individual resistors are measured or when groups of resistors connected in parallel are used, the leakage effects can be avoided by making three-terminal (guarded) measurements. When groups of resistors are connected in series, however, the effects cannot be avoided. Figure 4-4 shows the leakage effects for ten resistors connected in series and in parallel. The circuit was analyzed assuming that all leakage resistances were equal as shown, as this should reasonably reflect the actual leakage resistance on an SR1060.

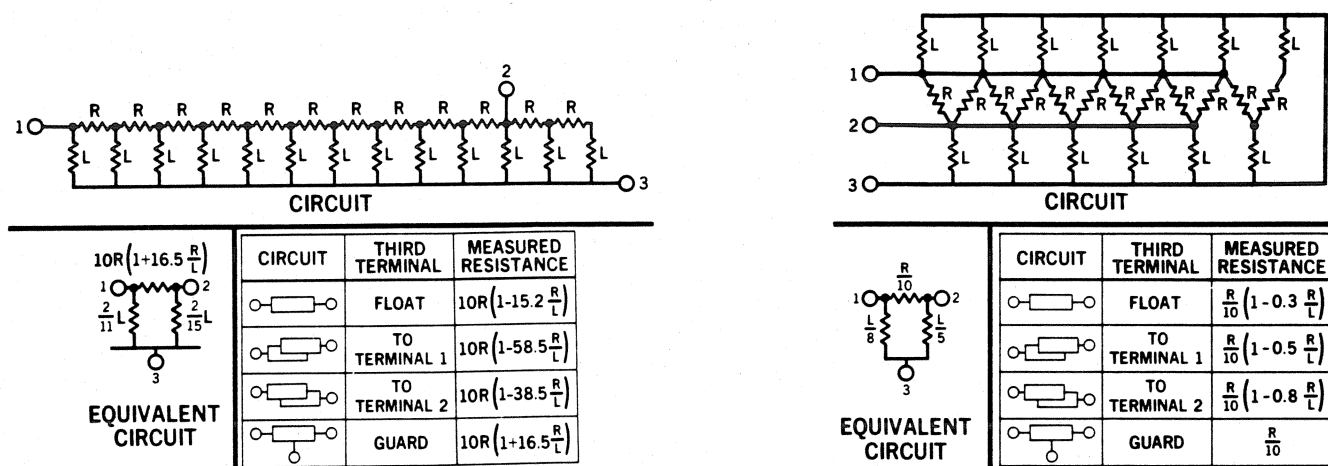

Figure 4-4. Effects of Leakage

The analysis indicates that the measured series resistance will be low if the case is not tied to guard and will be high if the resistors are guarded. The actual effect for a given measurement can be checked by making these two measurements and comparing the results. The correct value will lie somewhere between them.

With the 100 kilohm-per-step Resistor Bank, the error may be on the order of a ppm. With the other Resistor Banks, the error should be negligible. The ESI Model SR1050 Resistance Transfer Standards have been designed to avoid this terminal leakage and they are useful to the 10 megohm-per-step level with negligible leakage errors.

#### 4.2.1 Derivation of Series Circuit Leakage Resistance Effects

Figure 4-4 contains a series circuit equivalent circuit and three equations that relate to this circuit. The purpose of this section is to indicate how these were derived.

The process for deriving the equivalent circuit for the series connected resistors relies on the use of a "T to pi" transform. It can be shown that a three-terminal "T" resistor network (Figure 4-5a) can be transformed to a three-terminal "pi" resistor network (Figure 4-5b), or the "pi" network may be transformed to the "T" network. The equations in Figure 4-5 indicate how the values of the individual resistors transform between the two networks. Each network will have exactly the same characteristics for any measurement using only the three terminals.

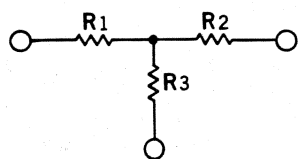

$$R_1 = \frac{R_A R_C}{R_A + R_B + R_C}$$

$$R_2 = \frac{R_A R_B}{R_A + R_B + R_C}$$

$$R_3 = \frac{R_B R_C}{R_A + R_B + R_C}$$

(a)

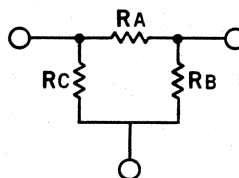

$$R_A = R_1 + R_2 + \frac{R_1 R_2}{R_3}$$

$$R_B = R_2 + R_3 + \frac{R_2 R_3}{R_1}$$

$$R_C = R_1 + R_3 + \frac{R_1 R_3}{R_2}$$

(b)

Figure 4-5. Transforming Between "T" and "Pi" Networks

The circuit composed of the twelve series resistors with thirteen leakage resistors to terminal 3 can be grouped into six "T" networks plus seven leakage resistors. This is shown in Figure 4-6.

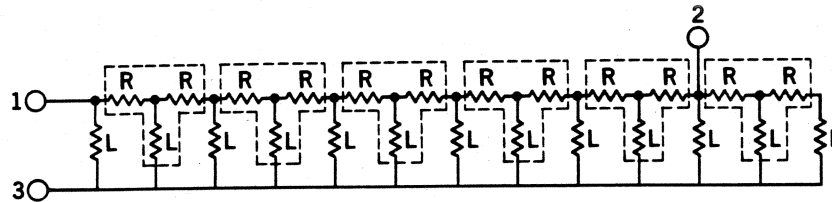

Figure 4-6. Grouping for the First Transform

Each "T" network has resistors of value R for the two horizontal arms and one resistor of value L for the vertical arm. Figure 4-7 indicates how this "T" network transforms into a "pi" network.

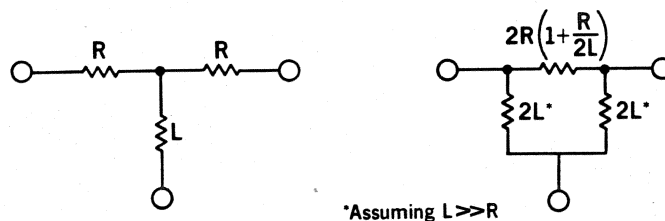

Figure 4-7. First "T" to "Pi" Transform



Replacing the original six "T" networks with the new "pi" networks results in the equivalent circuits shown in Figure 4-8. Figure 4-8b combines the parallel resistors composed of the remaining leakage resistors and the vertical arms of the "pi" networks. The two "T" networks that will be transformed in the next step are outlined in Figure 4-8b.

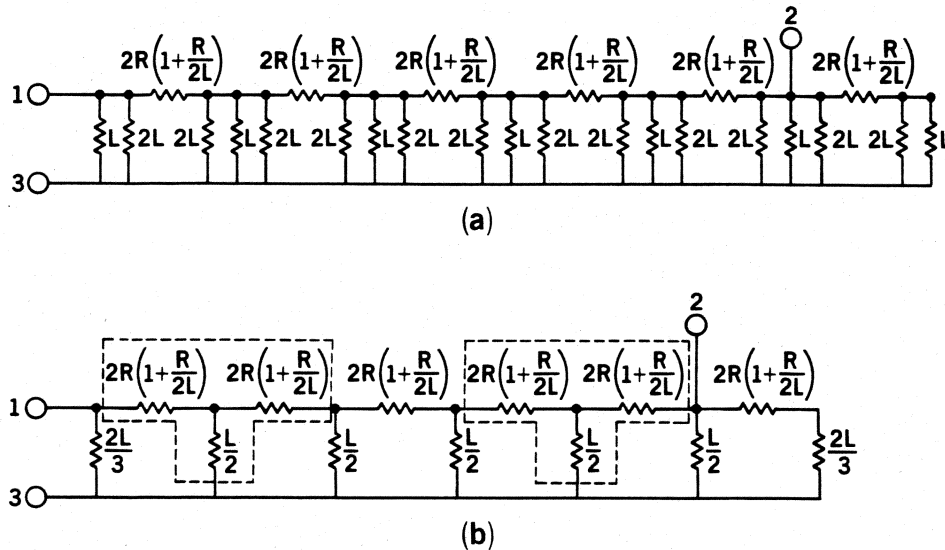

Figure 4-8. Result of First Transform

Each "T" network in Figure 4-8b has resistors of value  $2R(1 + R/2L)$  for the two horizontal arms and one resistor of value  $L/2$  for the vertical arm. Figure 4-9 indicates how this "T" network transforms into a "pi" network.

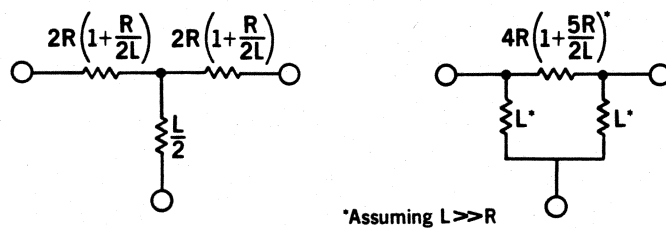

Figure 4-9. Second "T" to "Pi" Transform

Replacing the three "T" networks with the new "pi" networks results in the equivalent circuits shown in Figure 4-10. Figure 4-10b combines the parallel resistors composed of the remaining leakage resistors and the vertical arms of the "pi" networks. The vertical resistor on the far right is the parallel combination of the resistors to the right of Terminal 2 and the resistors from Terminal 2 to Terminal 3. The second series resistor from the left has been divided into two equal-value resistors for the next step. The two "T" networks that will be transformed in the next step are outlined in Figure 4-10b.

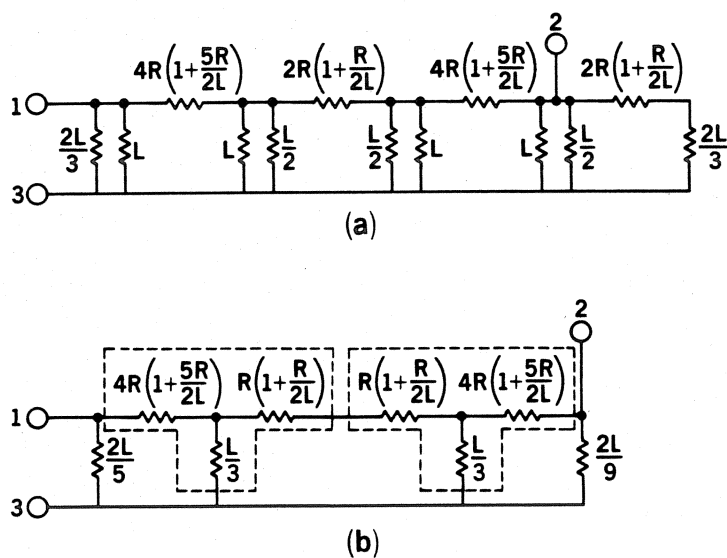

Figure 4-10. Result of Second Transform

The two "T" networks outlined in Figure 4-10b can be transformed into "pi" networks, as shown in Figure 4-11.

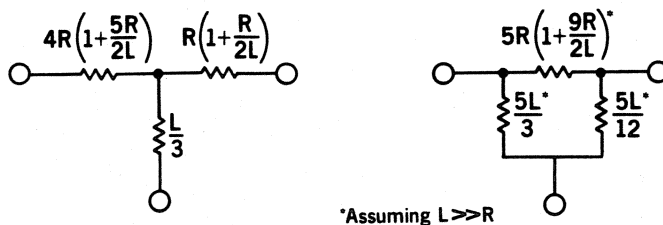

Figure 4-11. Third "T" to "Pi" Transform

The result of the third transform is shown in Figure 4-12.

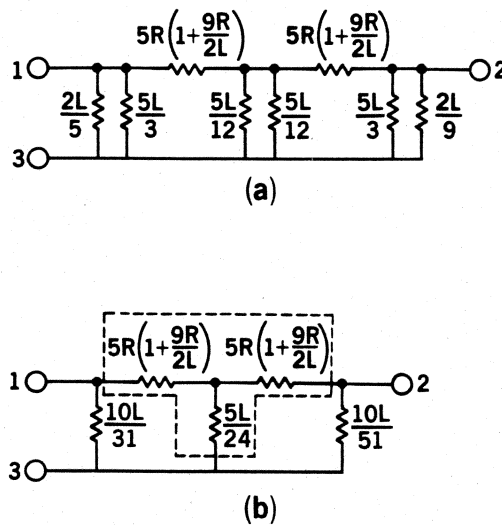

Figure 4-12. Result of Third Transform

The circuit shown in Figure 4-12b is composed of one "T" network with one extra resistor at each end. The "T" network can be transformed as shown in Figure 4-13.

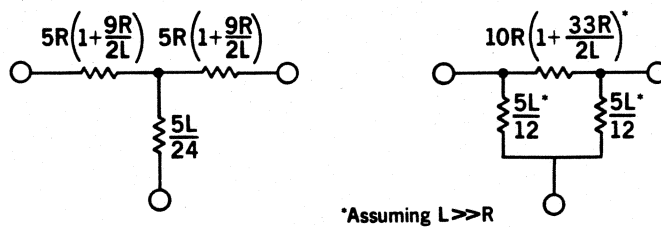
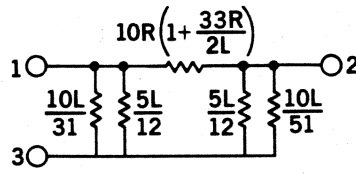
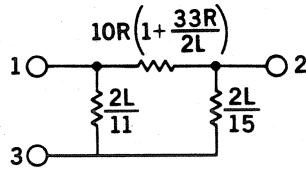

Figure 4-13. Fourth "T" to "Pi" Transform

The result of the last transform is shown in Figure 4-14. Figure 4-14b is the equivalent circuit used for the series case in Figure 4-4.



(a)



(b)

Figure 4-14. Result of Fourth Transform

#### 4.2.1.1 Series Circuit with Floating Terminal 3

To derive the three measured resistances, the result of a measurement on the equivalent circuit should be analyzed. In the case where terminal 3 floats, the two vertical resistors are in series with one another and in parallel with the horizontal resistor. This is shown in Figure 4-15.

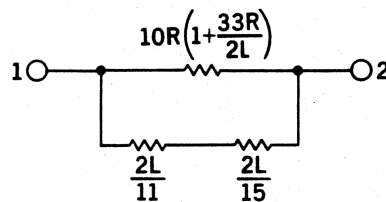

**Figure 4-15. Series Equivalent Circuit with Floating Terminal 3**

The measured value of this arrangement is given by:

$$R_f = \frac{10R (1 + 16.5 R/L) (2L/11 + 2L/15)}{10R (1 + 16.5 R/L) + (2L/11 + 2L/15)}$$

$$R_f = \frac{10R (1 + 16.5 R/L) 52L/165}{52L/165 + 165 R^2/L + 10R}$$

$$R_f = \frac{10R (1 + 16.5 R/L)}{1 + (27225/52) (R/L)^2 + (1650/52) (R/L)}$$

L would typically be at least  $10^7$  times larger than R, so  $(R/L)^2$  should be less than  $10^{-14}$ . Compared to the 1 in the denominator, the  $(R/L)^2$  term in the denominator should be insignificant and therefore can be ignored. This leaves:

$$R_f = \frac{10R (1 + 16.5 R/L)}{1 + (1650/52) (R/L)} = \frac{10R (1 + 16.5 R/L)}{1 + (825/26) (R/L)}$$

or

$$R_f = 10R (1 + 16.5 R/L) * \frac{1}{1 + (825/26) (R/L)}$$

Using the relationship (which converges over the region  $-1 < x < 1$ ):

$$\frac{1}{(1+x)} = 1 - x + x^2 - x^3 + \dots = 1 + \sum_{m=1}^{+\infty} (-x)^m$$

with  $x = (825/26) (R/L)$ :

$$R_f = 10R(1 + 16.5 R/L) (1 - (825/26) (R/L) + (825/26)^2 (R/L)^2 - \dots)$$

Again, the  $(R/L)^2$  and higher terms can be ignored, leaving:

$$R_f = 10R(1 + 16.5 R/L) (1 - (825/26) (R/L))$$

$$R_f = 10R(1 + R/L (16.5 - (825/26))) - 16.5 * (825/26) (R/L)^2$$

Again, the  $(R/L)^2$  and higher terms can be ignored, leaving:

$$R_f = 10R(1 + R/L (16.5 - (825/26))) = 10R(1 - R/L (198/13))$$

#### 4.2.1.2 Series Circuit with Terminal 3 Connected to Terminal 1

In the case where terminal 3 is connected to terminal 1, the resistor with value  $2L/11$  is shorted and the resistor with value  $2L/15$  is in parallel with the horizontal resistor. The measured resistance in this case is given by:

$$R_{13} = \frac{10R (1 + 16.5 R/L) (2L/15)}{10R (1 + 16.5 R/L) + (2L/15)}$$

$$R_{13} = \frac{10R (1 + 16.5 R/L)}{1 + 75R/L (1 + 16.5 R/L)} = \frac{10R (1 + 16.5 R/L)}{1 + 75R/L + 1237.5 (R/L)^2}$$

Again, the  $(R/L)^2$  term can be ignored, so:

$$R_{13} = \frac{10R (1 + 16.5 R/L)}{1 + 75R/L}$$

Using the  $1/(1+x)$  relationship again ( $x = 75R/L$ ) and ignoring terms above  $R/L$ :

$$R_{13} = 10R (1 + 16.5 R/L) (1 - 75R/L)$$

$$R_{13} = 10R (1 + 16.5 R/L - 75 R/L - (16.5 * 75) (R/L)^2)$$

Ignoring the  $(R/L)^2$  term:

$$R_{13} = 10R (1 - 58.5 R/L)$$

#### 4.2.1.3 Series Circuit with Terminal 3 Connected to Terminal 2

In the case where terminal 3 is connected to terminal 2, the resistor with value  $2L/15$  is shorted and the resistor with value  $2L/11$  is in parallel with the horizontal resistor. The measured resistance in this case is given by:

$$R_{12} = \frac{10R (1 + 16.5 R/L) (2L/11)}{10R (1 + 16.5 R/L) + (2L/11)}$$

$$R_{12} = \frac{10R (1 + 16.5 R/L)}{1 + 55R/L (1 + 16.5 R/L)} = \frac{10R (1 + 16.5 R/L)}{1 + 55R/L + 907.5 (R/L)^2}$$

Again, the  $(R/L)^2$  term can be ignored, so:

$$R_{12} = \frac{10R (1 + 16.5 R/L)}{1 + 55R/L}$$

Using the  $1/(1 + x)$  relationship again ( $x = 55R/L$ ) and ignoring terms above  $R/L$ :

$$R_{12} = 10R (1 + 16.5 R/L) (1 - 55R/L)$$

$$R_{12} = 10R (1 + 16.5 R/L - 55 R/L - (16.5 * 55) (R/L)^2)$$

Ignoring the  $(R/L)^2$  term:

$$R_{12} = 10R (1 - 38.5 R/L)$$

#### 4.2.1.4 Series Circuit with Terminal 3 Guarded

If a proper three-terminal measurement is made, the effects of the vertical resistors in the equivalent circuit will be eliminated. The result will be that the measured resistance will be the value of the horizontal resistor in the equivalent circuit,  $10R(1 + 16.5R/L)$ . Connecting terminal 3 to a GUARD terminal on the bridge, a good approximation of a three-terminal connection can be made.

### 4.2.2 Derivation of Parallel Circuit Leakage Resistance Effects

The parallel resistance case is simpler than the series resistance case. Assuming equal leakage for all junctions, the circuit appears as shown in Figure 4-16.

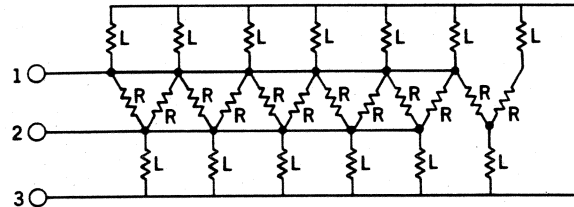

Figure 4-16. Parallel Configuration with Leakage Resistances

Combining the parallel resistors of Figure 4-16 results in the circuit shown in Figure 4-17a. The two resistors of value R (outlined in Figure 4-17a) can be replaced by short circuits as they are in series with resistors with value L and L is much greater than R. This substitution results in the equivalent circuit shown in Figure 4-17b.

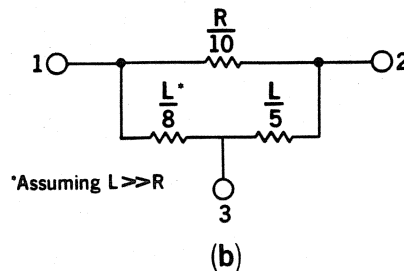
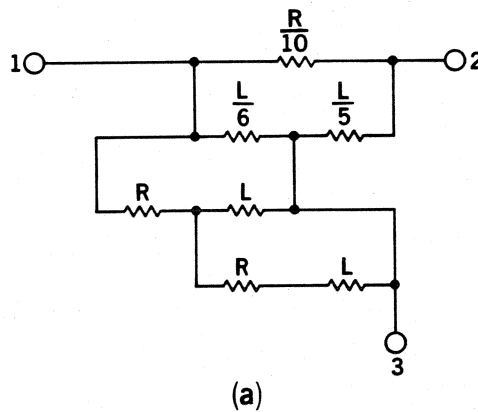
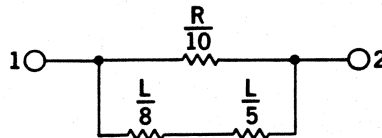

Figure 4-17. Parallel Configuration Simplified



#### 4.2.2.1 Parallel Circuit with Floating Terminal 3

If terminal 3 of the parallel circuit is allowed to float, the two vertical resistors in the equivalent circuit are in series with one another and in parallel with the horizontal resistor. This is shown in Figure 4-18.



**Figure 4-18. Parallel Equivalent Circuit with Floating Terminal 3**

The measured value of this arrangement is given by:

$$R_f = \frac{(R/10) (L/8 + L/5)}{(R/10) + (L/8 + L/5)} = \frac{(R/10) (13L/40)}{(R/10) + (13L/40)}$$
$$R_f = \frac{R/10}{1 + (4/13)(R/L)}$$

Using the  $1/(1 + x)$  equation ( $x = 4/13 R/L$ ) and ignoring  $(R/L)^2$  terms:

$$R_f = (R/10) (1 - (4/13)(R/L))$$

#### 4.2.2.2 Parallel Circuit with Terminal 3 Connected to Terminal 1

In the case where terminal 3 is connected to terminal 1, the resistor with value  $L/8$  is shorted and the resistor with value  $L/5$  is in parallel with the horizontal resistor. The measured resistance in this case is given by:

$$R_f = \frac{(R/10) (L/5)}{(R/10) + (L/5)} = \frac{R/10}{1 + (1/2) (R/L)}$$

Using the  $\frac{1}{1+x}$  equation and ignoring  $(R/L)^2$  terms:

$$R_f = (R/10) (1 - (1/2) (R/L))$$

#### 4.2.2.3 Parallel Circuit with Terminal 3 Connected to Terminal 2

In the case where terminal 3 is connected to terminal 2, the resistor with value  $L/5$  is shorted and the resistor with value  $L/8$  is in parallel with the horizontal resistor. The measured resistance in this case is given by:

$$R_f = \frac{(R/10) (L/8)}{(R/10) + (L/8)} = \frac{R/10}{1 + (4/5) (R/L)}$$

Using the  $\frac{1}{1+x}$  equation and ignoring  $(R/L)^2$  terms:

$$R_f = (R/10) (1 - (4/5) (R/L))$$

#### 4.2.2.4 Parallel Circuit with Terminal 3 Guarded

If terminal 3 is connected to a Guard on the bridge, the effects of the vertical resistors in the equivalent circuit will be eliminated. The result will be that the measured resistance will be the value of the horizontal resistor in the equivalent circuit,  $R/10$ .

### 4.3 TRANSFER ACCURACY

To make transfer measurements which do not depend on the absolute accuracy of the transfer standard but only on its short-term stability, it is necessary to assume that ten resistors in parallel are exactly equal to one one-hundredth of the same ten resistors in series. To see how valid this assumption is, let  $R$  be the nominal value of the individual resistors and  $d_n$  the deviation from nominal of the  $n$ th resistor. The value of the  $n$ th resistor will then be:  $R_n = R(1 + d_n)$ . The value of the ten resistors in series will be:

$$R_s = \sum_{n=1}^{10} R(1 + d_n) = 10R \left(1 + \frac{1}{10} \sum_{n=1}^{10} d_n\right)$$
$$d_{av}^{10} = \frac{1}{10} \sum_{n=1}^{10} d_n$$

Where:

$d_{av}^{10}$  is the average of the deviation  $d_n$  for ten resistors

So:

$$R_s = 10R \left(1 + d_{av}^{10}\right)$$

The resistance of the same ten resistors in parallel will be:

$$R_p = \frac{1}{\sum_{n=1}^{10} \frac{1}{R(1 + d_n)}}$$

This can be calculated if the individual deviations are known. For the general case where the deviations are unknown, the equation can be solved further.

#### 4.4 COMPENSATION NETWORKS

To minimize the effects of the connections when using a parallel or series-parallel arrangement, Compensation Networks and Shorting Bars are available. Their affect on the measurement is discussed in this section.

The parallel connection of ten four-terminal resistors using the SB103 Shorting Bars and the PC101 Parallel Compensation Network is shown in Figure 4-19.

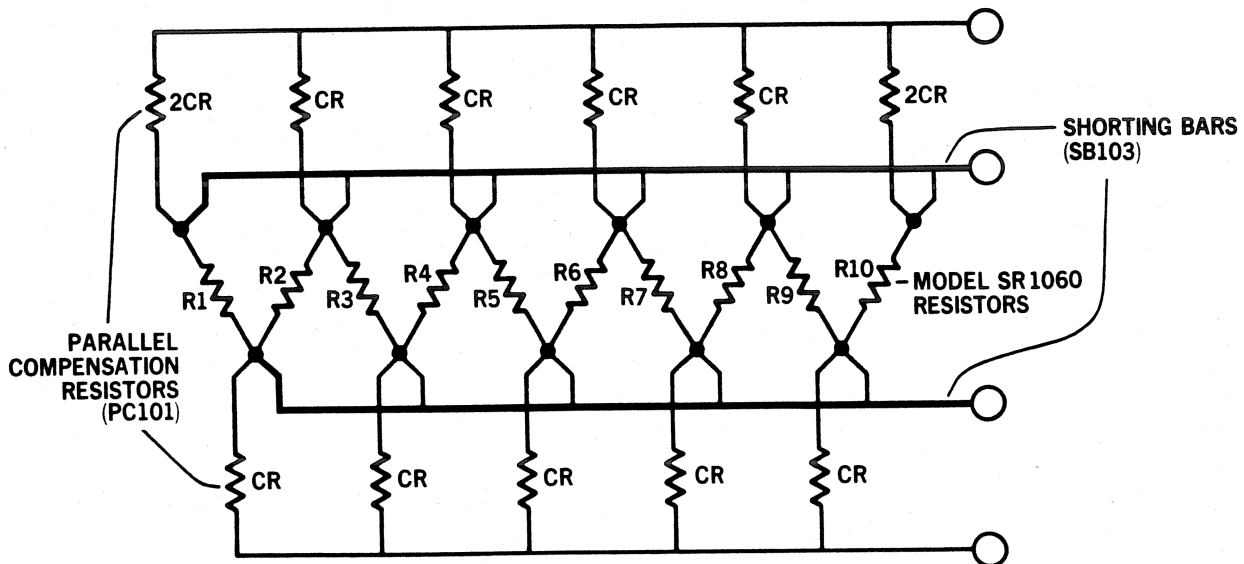

Figure 4-19. Parallel Connection with Shorting Bars and Compensation Network

The Shorting Bar resistance and the resistance from the junctions to the Shorting Bars should be small. The compensation resistors in the Compensation Network should be large compared to the uncertainty in the contact resistances when they are connected. The two compensation resistors on the ends are double the others because they connect to one SR1060 resistor instead of two in parallel.

When several nominally equal resistors are connected in parallel the connection accuracy can be analyzed by looking at the worst case. This is done by assuming that all of the compensation resistors except one are equal and that all of the Shorting Bar resistances except one are zero. At the same time, all of the resistors being connected are assumed to be perfect except one. The three imperfect resistors all meet at one of the junctions. Since small first-order error effects add linearly, the results of this analysis can be extended to determine the connection accuracy. The connection uncertainty is less than:

$$\pm 2 \left( \frac{r}{R} \right) (d_{CR} - d_R)$$

Where:

r is the greatest bus bar resistance  
 R is the nominal value of resistors being parallel connected  
 $(d_{CR} - d_R)$  is the greatest bridge unbalance in terms of  
 resistance deviations of the compensation resistors and  
 the resistors being connected

**NOTE:** Proof of the equation given above and those that follow can be found in ESI Technical Article TA-6, "The Accuracy of Series and Parallel Connections of Four-Terminal Resistors," available directly from ESI.

The values of  $r/R$  and  $(d_{CR} - d_R)$  can be measured to find the expected accuracy of a particular connection.

The value of  $r/R$  can be found by measuring the voltage drops from a point on the Shorting Bars to the junction of adjacent resistors, shown in Figure 4-20. This is done as follows.

- STEP 1. Connect the Shorting Bars and a DC Generator to the bank of resistors for parallel use, as shown in Figure 4-20.
- STEP 2. Connect one lead of a voltmeter to one of the terminals on one of the Shorting Bars, as shown in Figure 4-20.
- STEP 3. Measure and record the voltage to the terminal across from each terminal connected to the selected Shorting Bar. Calculate the largest difference between these voltages.
- STEP 4. Repeat STEPS 2 and 3 for the other Shorting Bar.
- STEP 5. Divide the higher of the two voltage differences calculated in STEPS 3 and 4 by  $E$ , the voltage of the DC Generator.

The value calculated in STEP 5 is the upper limit of  $(r/R)$ , the upper limit of the error of a four-terminal measurement when the Shorting Bars are used without the Compensation Network, and is given by:

$$\left(\frac{r}{R}\right)_{\max} = \frac{V_{\max} - V_{\min}}{E}$$

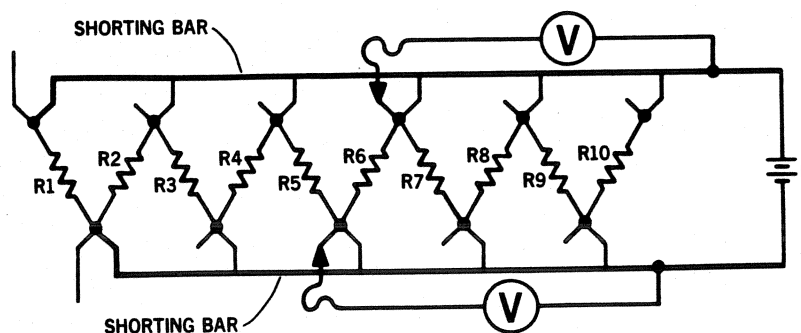

Figure 4-20. Measuring  $r/R$

The value of  $(d_{CR} - d_R)$ , the bridge unbalance, is measured in the following manner. Refer to Figure 4-21.

STEP 1. Connect one Shorting Bar to terminals C1 through C5. Connect the PC101 Compensation Network and a DC Generator to the bank of resistors for parallel use.

STEP 2. Connect one lead of a voltmeter to terminal A10.

STEP 3. Measure and record the voltage to each of the five terminals A0 through A8. Subtract the highest voltage from the lowest voltage to calculate the largest difference.

STEP 4. Move the Shorting Bar to terminals A0 through A10.

STEP 5. Connect one lead of the voltmeter to terminal C5.

STEP 6. Measure and record the voltage to each of the four terminals C1 through C4. Subtract the highest voltage from the lowest voltage to calculate the largest difference.

STEP 7. Divide the higher of the two voltage differences calculated in STEPS 3 and 6 by E, the voltage of the DC Generator.

The value calculated in STEP 7 is given by:

$$(d_{CR} - d_R)_{\max} = \left( \frac{V_{\max} - V_{\min}}{E} \right) \left( 2 + \frac{2CR}{R} + \frac{R}{CR} \right)$$

The measured values of  $(r/R)_{\max}$  and  $(d_{CR} - d_R)_{\max}$  can be multiplied together and doubled to give an upper bound of the connection error. This usually includes a very substantial safety factor. The same technique can be used in the series-parallel case.

**NOTE:** With the PC101 and SPC102 Compensation Networks, the connection uncertainty just calculated should always be negligibly small.

The bridge unbalance can be measured as shown in Figure 4-21.

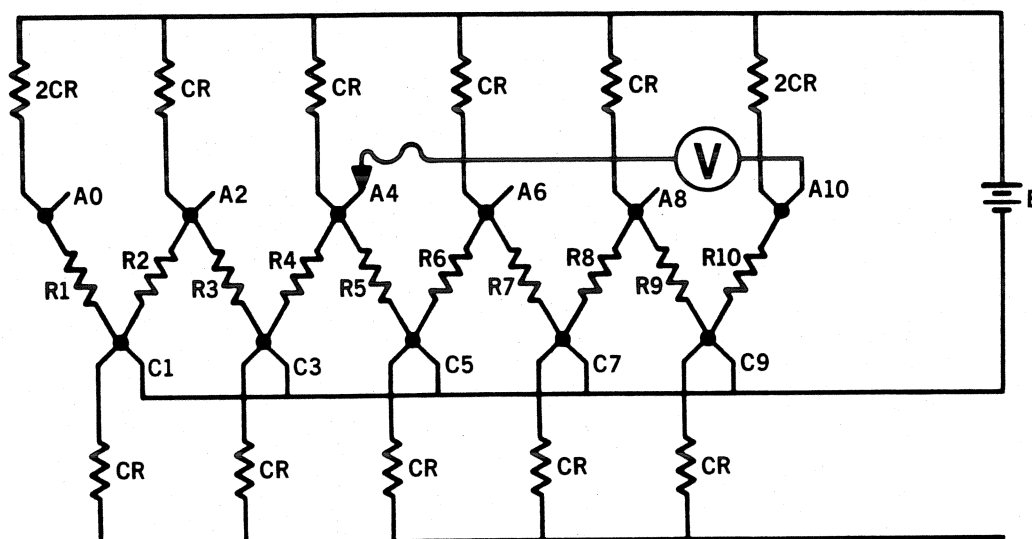

**Figure 4-21. Measuring the Bridge Unbalance**



#### 4.5 LINEARITY DEVIATION

To calibrate the SR1060 as a voltage divider, the difference between the actual ratio of the output to input voltages and the setting must be determined. This difference, called linearity deviation, is given by the following.

$$L = \frac{E_{out}}{E_{in}} - S$$

Where:

L is the linearity deviation  
 $E_{in}$  is the actual input voltage  
 $E_{out}$  is the actual output voltage  
 S is the divider setting

Since the voltage and resistance divide proportionately, the linearity deviation can be found by a precision comparison of the resistors in the divider string. By using ten resistors of the SR1060 in the divider string, the output can be set to integral multiples of a tenth the input voltage. The linearity deviation for this divider can be written as:

$$L = \frac{\sum_{i=1}^n R_i}{\sum_{i=1}^{10} R_i} - S = \frac{\sum_{i=1}^n R (1 + d_i)}{\sum_{i=1}^{10} R (1 + d_i)} - S = \frac{\sum_{i=1}^n (1 + d_i)}{\sum_{i=1}^{10} (1 + d_i)} - S$$

Where:

L is the linearity deviation  
 $R_i$  is the resistance of the  $i$ th resistor  
 $\sum_{i=1}^n R_i$  is the resistance from the Output to the COMMON terminal  
 $\sum_{i=1}^{10} R_i$  is the total input resistance  
 S is the divider setting ( $0 \leq S \leq 1$ )  
 n is the number of resistors between the Output and the COMMON terminal (= 10S)

To simplify further:

$$L = \frac{10S + \sum_{i=1}^n d_i}{10 + \sum_{i=1}^r d_i} - S$$

The cumulative deviation (at the rth resistor) is defined as:

$$d_{cu}^r = \frac{1}{r} \sum_{i=1}^r d_i$$

The following has already been defined as the average deviation:

$$d_{cu}^{10} = d_{av}^{10} = 0.1 \sum_{i=1}^{10} d_i$$

So, noting that  $n = 10S$ :

$$L = \frac{n + n d_{cu}^n}{10 + 10 d_{av}^{10}} - \frac{n}{10} = \frac{n}{10} \left( \frac{1 + d_{cu}^n}{1 + d_{av}^{10}} - 1 \right)$$

$$L = \frac{n}{10} \left( \frac{1 + d_{cu}^n - 1 - d_{av}^{10}}{1 + d_{av}^{10}} \right) = \frac{n}{10} \left( \frac{d_{cu}^n - d_{av}^{10}}{1 + d_{av}^{10}} \right)$$

Assuming that  $d_{av}^{10} \ll 1$ :

$$L = \frac{n}{10} (d_{cu}^n - d_{av}^{10})$$

## SECTION 5

# APPLICATIONS

This section illustrates applications of the SR1060 by describing step-by-step resistance transfer procedures for typical instruments. The transfer techniques may be used as a method of calibrating the individual resistors in a transfer standard, to calibrate other resistors, or to calibrate the measuring instruments themselves.

The techniques shown here are intended as examples. They illustrate the way that the SR1060 can be used. One can adapt the techniques illustrated here to other equipment.

**NOTE:** Reference is made in this following procedures to a **tare** resistor. A tare resistor is one that is used as an external part of a measuring bridge and is left connected throughout the calibration and measuring process. Its value does not need to be accurate, but it must have good short-term stability.

## 5.1 ESI MODEL 123 RESISTANCE COMPARISON SYSTEM\*

### 5.1.1 System Description

ESI Model 123 Resistance Comparison System consists of ESI Models 120 Direct-Reading Double Ratio Set, 876 Lead Compensator, 830 Generator, and 900 Galvanometer. Refer to Figure 5-1.

This system uses a Wenner balance technique that eliminates errors that are due to resistance of the test leads. The resolution of the OFFSET and RATIO dials of the ratio set is 0.1 ppm. The galvanometer can be used to interpolate to 0.01 ppm throughout much of the range.

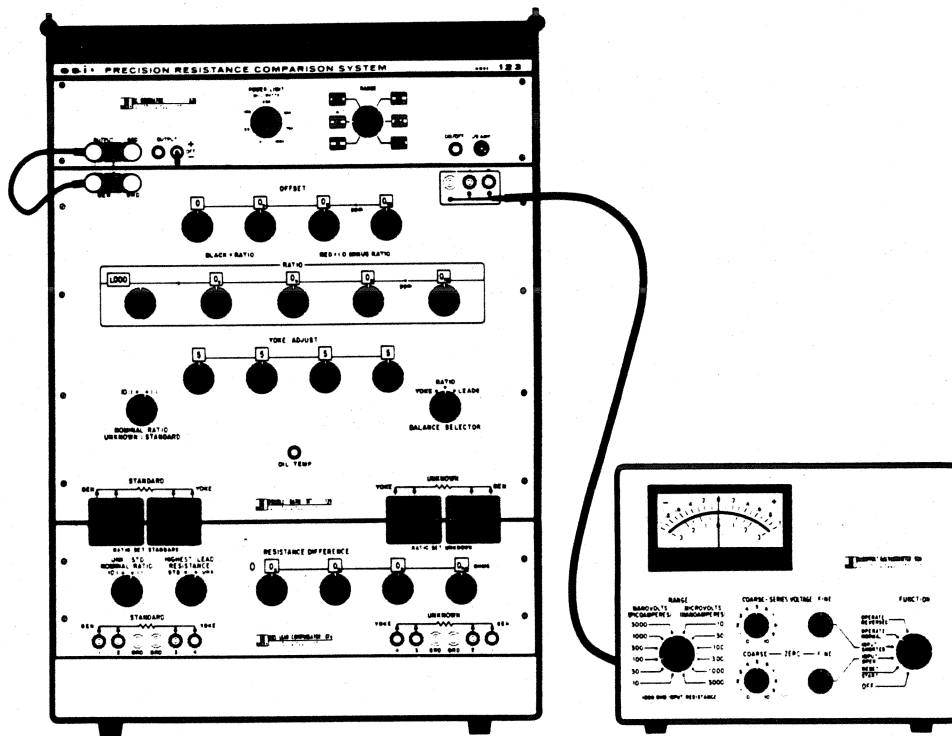

Figure 5-1. ESI Model 123

\*The ESI Model 123 is no longer being manufactured.

The accuracy of comparisons can be illustrated by the following example, in which a 10 kilohm standard value is transferred to 1 ohm. The error of each step of the transfer procedure is independent of the other steps and so the combination of errors is shown as the square root of the sum of the squares of the individual errors.

This example is taken from paragraph 5.1.5 following. The individual limits of error are those specified for the equipment used.

<u>Source of Error</u>	<u>Limit of Error (ppm)</u>
1. Primary Standard (ESI Model SR104 10 kilohm Resistance Standard)	1.0
2. Comparison of Resistance Standard to tare resistor (using ESI Model 123 System)	0.22
3. Comparison of tare resistor to 1 kilohm-per-step SR1060 Resistor Bank	0.22
4. 100-to-1 transfer	1.0
5. Comparison of 1 kilohm-per-step (parallel connected) SR1060 Resistor Bank to 100 ohm tare resistor	0.22
6. Comparison of 100 ohm tare resistor to 10 ohm-per-step (series connected) SR1060 Resistor Bank	0.22
7. 100-to-1 transfer	1.1
8. Comparison of 10 ohm-per-step (parallel connected) SR1060 Resistor Bank to 1 ohm tare resistor	0.22
9. Comparison of 1 ohm tare resistor to unknown 1 ohm resistor	0.22
	—
Sum of Error Limits	4.42 ppm
Square root of the sum of the squares	1.87 ppm

**NOTE:** If the individual steps are independent and normally distributed, the square root of the sum of squares should be used as the total uncertainty.

**NOTE:** Exact details of operating the system are not covered in these procedures. The detector must be zeroed with the generator off but with the resistors to be compared connected to the UNKNOWN and STANDARD binding posts, the yoke and leads must be balanced according to the procedure in the manual for the ratio set, the generator polarity must be reversed to avoid thermal voltage errors, and the detector sensitivity must be increased after each trial balance. All of these operations are included in the single word "balance" in the following procedures.

### 5.1.2 Transfer from 10 kilohms to 100 kilohms and 1 kilohm

- STEP 1. Connect the 10 kilohm primary standard resistor (ESI Model SR104 is recommended) to the UNKNOWN binding posts of the Lead Compensator. Use a four-terminal connection to the resistor and connect at least one GND terminal on the standard resistor to a GND terminal on the bridge.
- STEP 2. Set RATIO controls of the ratio set to the calibrated resistance (correct for temperature) of the standard. ESI Model SR104 contains an internal resistance temperature sensor which changes by 0.1% (1000 ppm) per degree Celsius. A calibration curve is included with the standard resistor.
- STEP 3. Connect the tenth resistor (R10) of the 10 kilohm-per-step SR1060 Resistor Bank to the STANDARD binding posts of the Lead Compensator.
- STEP 4. Balance the bridge with the OFFSET dials. Do NOT adjust the RATIO dials. Record the OFFSET dial reading as d(10).
- STEP 5. Connect the 10 kilohm-per-step SR1060 Resistor Bank in series-parallel for 10 kilohms and connect the transfer standard to the STANDARD terminals of the Lead Compensator.
- STEP 6. Balance the bridge with the OFFSET dials. Do NOT adjust the RATIO dials. Record the reading as d(9).

STEP 7. Set the OFFSET dials to the setting calculated by:

$$\frac{d(10) + 9d(9)}{10}$$

**NOTE:** Use STEPS 8 to 10 to calibrate 100 kilohm resistors. To calibrate 1 kilohm resistors, proceed to STEP 11.

STEP 8. Disconnect Shorting Bars from the 10 kilohm-per-step SR1060 Resistor Bank and connect its first 10 resistors in series to the STANDARD terminals of the Lead Compensator.

STEP 9. Connect the 100 kilohm resistor to be calibrated to the UNKNOWN terminals of the Lead Compensator.

STEP 10. Balance the bridge with the RATIO dials. The indication of the RATIO dials is the ratio of the 100 kilohm resistor to the actual value of 100 kilohms as transferred from the primary standard. (Only the last two STEPS need be repeated for each resistor of a group of 100 kilohm resistors.)

**NOTE:** Use STEPS 11 to 13 to calibrate 1 kilohm resistors.

STEP 11. Connect the first ten resistors of the 10 kilohm-per-step SR1060 Resistor Bank in parallel, using the Shorting Bars. Connect the parallel combination to the STANDARD terminals of the Lead Compensator.

STEP 12. Connect the 1 kilohm resistor to be calibrated to the UNKNOWN terminals of the Lead Compensator.

STEP 13. Balance the bridge with the RATIO dials. The indication of the RATIO dials is the ratio of the 1 kilohm resistor to the actual value of 1 kilohm as transferred from the primary standard. (Only the last two STEPS need be repeated for each resistor of a group of 1 kilohm resistors.)

### 5.1.3 Transfer from 10 kilohms to 100 ohms

- STEP 1. Connect the 10 kilohm primary standard resistor (ESI Model SR104 is recommended) to the UNKNOWN binding posts of the Lead Compensator. Use a four-terminal connection and connect at least one GND terminal on the standard resistor to a GND terminal on the bridge.
- STEP 2. Set the RATIO controls of the ratio set to the calibrated resistance of the standard. Be sure to correct this setting for temperature. ESI Model SR104 contains an internal resistance temperature sensor which changes by 0.1% (1000 ppm) per degree Celsius. A calibration curve is included with the standard resistor.
- STEP 3. Connect the first ten resistors of a 1 kilohm-per-step SR1060 Resistor Bank in series, 10 kilohms, to the STANDARD binding posts of the Lead Compensator.
- STEP 4. Balance the bridge with the OFFSET dials. Do NOT adjust the RATIO dials.
- STEP 5. Connect the first ten resistors of the 1 kilohm-per-step SR1060 Resistor Bank in parallel, using the Shorting Bars. Connect the parallel combination to the STANDARD binding posts of the Lead Compensator.
- STEP 6. Connect the 100 ohm resistor to be calibrated to the UNKNOWN binding posts of the Lead Compensator.
- STEP 7. Balance the bridge with the RATIO dials. The indication of the RATIO dials is the ratio of the 100 ohm resistor to the actual value of 100 ohms as transferred from the primary standard.



#### 5.1.4 Transfer from 10 kilohms to 10 ohms

- STEP 1. Connect the 10 kilohm primary standard resistor (ESI Model SR104 is recommended) to the UNKNOWN binding posts of the Lead Compensator. For this and the following measurements use a four-terminal connection to the resistor and connect at least one GND terminal on the standard resistor to a GND terminal on the bridge.
- STEP 2. Set the RATIO dials of the Ratio Set to the calibrated resistance value of the standard. Be sure to correct this setting for temperature. The ESI Model SR104 contains an internal resistance temperature sensor which changes by 0.1% (1000 ppm) per degree Celsius. A calibration curve is included with the standard resistor.
- STEP 3. Connect ten resistors of the 1 kilohm-per-step SR1060 Resistor Bank in series, 10 kilohms, to the STANDARD binding posts of the Lead Compensator. (This resistance is used only as a tare. Any highly stable 10 kilohm resistor can be used instead of the transfer standard.)
- STEP 4. Balance the bridge with the OFFSET dials. Do NOT adjust the RATIO dials. (This calibrates the bridge for measuring 10 kilohm resistors.)
- STEP 5. Connect the tenth resistor (R10) of the 10 kilohm-per-step SR1060 Resistor Bank to the UNKNOWN binding posts of the Lead Compensator.

- STEP 6. Balance the bridge with the RATIO dials. Do NOT adjust the OFFSET dials. Record the deviation part of the reading of the RATIO dials as  $d(10)$ . (This gives the deviation of  $R_{10}$  from the calibrated value of 10 kilohms.)
- STEP 7. Connect the 10 kilohm-per-step SR1060 Resistor Bank in series-parallel for 10 kilohms (refer to Section 3.1.3) and connect it to the UNKNOWN binding posts of the Lead Compensator.
- STEP 8. Balance the bridge with the RATIO dials. Do NOT adjust the OFFSET dials. Record the deviation part of the reading of the RATIO dials as  $d(9)$ . (This is the deviation of the series-parallel connected nine resistors from the calibrated value of 10 kilohms.)
- STEP 9. Set the deviation part of RATIO dials to the setting calculated by:

$$\frac{d(10) + 9d(9)}{10}$$

(This calculates the average deviation of the first ten resistors in the 10 kilohm-per-step SR1060 Resistor Bank.)

- STEP 10. Connect the first ten resistors of the 10 kilohm-per-step SR1060 Resistor Bank in parallel for 1 kilohm using the Shorting Bars. Connect this parallel combination, 1 kilohm, to the UNKNOWN binding posts of the Lead Compensator. (This provides a 1 kilohm standard which has the deviation calculated in STEP 9.)

- STEP 11. Connect the first nine resistors of the 1 kilohm-per-step SR1060 Resistor Bank in series-parallel for 1 kilohm using the Shorting Bars. Connect this 1 kilohm resistor to the STANDARD binding posts of the Lead Compensator to use as a 1 kilohm tare resistor.
- STEP 12. Balance the bridge with the OFFSET dials. Do NOT adjust the RATIO dials. (This calibrates the bridge for measuring 1 kilohm resistors.)
- STEP 13. Connect ten resistors of the 100 ohm-per-step SR1060 Resistor Bank in series, 1 kilohm, to the UNKNOWN binding posts of the Lead Compensator.
- STEP 14. Balance the bridge with the RATIO dials. Do NOT adjust the OFFSET dials. (This calibrates the average deviation of the first ten resistors in the 100 ohm-per-step SR1060 Resistor Bank.)
- STEP 15. Connect the first nine resistors of the 10 ohm-per-step SR1060 Resistor Bank in series-parallel for a 10 ohm tare resistor. Connect this tare resistor to the the STANDARD terminals of the Lead Compensator.
- STEP 16. Connect the first ten resistors of the 100 ohm-per-step SR1060 Resistor Bank in parallel for 10 ohms using the Shorting Bars. Plug the Model PC101 Parallel Compensation Network into the binding posts of this 100 ohm-per-step SR1060 Resistor Bank.

- STEP 17. Connect the binding posts of the Compensation Network to the outer UNKNOWN binding posts of the Lead Compensator (Network terminal 1 goes to Lead Compensator terminal 1, labeled GEN, and Network terminal 2 goes to Lead Compensator terminal 4, labeled YOKE). Note the arrows on the Compensation Network showing which Shorting Bar is associated with which Compensation Network terminal. Connect the Shorting Bar pointed to by NETWORK terminal 1 to Lead Compensator terminal 2 and the Shorting Bar pointed to by Network terminal 2 to Lead Compensator terminal 3.
- STEP 18. Balance the bridge with the OFFSET dials. Do NOT adjust the RATIO dials. (This calibrates the bridge for measuring 10 ohm resistors.)
- STEP 19. Connect the 10 ohm resistor to be calibrated to the UNKNOWN terminals of the Lead Compensator.
- STEP 20. Balance the bridge with the RATIO dials. The indication of the ratio dials is the ratio of the 10 ohm resistor to the actual value of 10 ohms as transferred from the 10 kilohm primary standard.

### 5.1.5 Transfer from 10 kilohms to 1 ohm

- STEP 1. Connect the 10 kilohm primary standard resistor (ESI Model SR104 is recommended) to the UNKNOWN binding posts of the Lead Compensator. For this and the following measurements use a four-terminal connection to the resistor and connect at least one GND terminal on the standard resistor to a GND terminal on the bridge.
- STEP 2. Set the RATIO dials of the Ratio Set to the calibrated resistance value of the standard. Be sure to correct this setting for temperature. The ESI Model SR104 contains an internal resistance temperature sensor which changes by 0.1% (1000 ppm) per degree Celsius. A calibration curve is included with the standard resistor.
- STEP 3. Use the Shorting Bars to connect ten resistors of 10 kilohm-per-step SR1060 Resistor Bank in series-parallel, 10 kilohms, to the STANDARD binding posts of the Lead Compensator. (This resistance is used only as a tare. Any highly stable 10 kilohm resistor can be used instead of the transfer standard.)
- STEP 4. Balance the bridge with the OFFSET dials. Do NOT adjust the RATIO dials. (This calibrates the bridge for measuring 10 kilohm resistors.)
- STEP 5. Connect ten resistors of the 1 kilohm-per-step SR1060 Resistor Bank in series, 10 kilohms, to the UNKNOWN binding posts of the Lead Compensator.

- STEP 6. Balance the bridge with the RATIO dials. Do NOT adjust the OFFSET dials. (This calibrates the average deviation of the first ten resistors in the 1 kilohm-per-step SR1060 Resistor Bank.)
- STEP 7. Connect ten resistors of the 100 ohm-per-step SR1060 Resistor Bank in series-parallel, 100 ohms, to the STANDARD binding posts of the Lead Compensator as a tare resistor.
- STEP 8. Using the Shorting Bars, connect the 1 kilohm-per-step SR1060 Resistor Bank that was calibrated in STEP 6 in parallel for 100 ohms and connect it to the UNKNOWN binding posts of the Lead Compensator.
- STEP 9. Balance the bridge with the OFFSET dials. Do NOT adjust the RATIO dials. (This calibrates the bridge for measuring 100 ohm resistors.)
- STEP 10. Connect the first ten resistors of the 10 ohm-per-step SR1060 Resistor Bank in series for 100 ohms. Connect this 100 ohm resistor to the UNKNOWN binding posts of the Lead Compensator.
- STEP 11. Balance the bridge with the RATIO dials. Do NOT adjust the OFFSET dials. (This measures the average deviation of the first ten resistors in the 10 ohm-per-step SR1060 Resistor Bank.)

- STEP 12. Connect the first ten resistors of the 10 ohm-per-step SR1060 Resistor Bank in parallel for 1 ohm using the Shorting Bars. Plug the Model PC101 Parallel Compensation Network into the binding posts of this 10 ohm-per-step SR1060 Resistor Bank.
- STEP 13. Connect the binding posts of the Compensation Network to the outer UNKNOWN binding posts of the Lead Compensator (Network terminal 1 goes to Lead Compensator terminal 1, labeled GEN, and Network terminal 2 goes to Lead Compensator terminal 4, labeled YOKE). Note the arrows on the Compensation Network showing which Shorting Bar is associated with which Compensation Network terminal. Connect the Shorting Bar pointed to by NETWORK terminal 1 to Lead Compensator terminal 2 and the Shorting Bar pointed to by Network terminal 2 to Lead Compensator terminal 3.
- STEP 14. Using the Shorting Bars, connect the first nine resistors of the 1 ohm-per-step SR1060 Resistor Bank in series-parallel for a 1 ohm tare resistor. Connect this tare resistor to the the STANDARD terminals of the Lead Compensator.
- STEP 15. Balance the bridge with the OFFSET dials. Do NOT adjust the RATIO dials. (This calibrates the bridge for measuring 1 ohm resistors.)
- STEP 16. Connect the 1 ohm resistor to be calibrated to the UNKNOWN terminals of the Lead Compensator.
- STEP 17. Balance the bridge with the RATIO dials. The indication of the ratio dials is the ratio of the 1 ohm resistor to the actual value of 1 ohm as transferred from the 10 kilohm primary standard.

## 5.2 ESI MODEL 242D RESISTANCE MEASUREMENT SYSTEM

**NOTE:** A more accurate version of the Model 242D, the Model SP3632, is also available. Its appearance and operation are the same as for the Model 242D.

### 5.2.1 System Description

The ESI Model 242D Resistance Measuring System consists of the Model 240C Kelvin Ratio Bridge, the Model RS925D Decade Resistance Standard, and the Model 801B DC Generator-Detector. The value of the resistor being measured is read as the product of the reading of the decade dials on the RS925D and the reading of the MULTIPLIER dial on the 240C (a power of 10). A DEVIATION dial is provided on the 240C for reading the difference between the actual ratio and the nominal ratio of the standard and unknown resistors.

### 5.2.2 Equipment Required

Model 242D Resistance Measuring System with KELVIN KLIPS®  
Four-Terminal Clips  
SR1060 with SB102 Shorting Bars and PC101 Parallel and  
SPC102 Series-Parallel Compensation Networks  
10 ohm Calibrated Standard Resistor (Value chosen as an  
example)  
100 ohm and 1 kilohm SR1 Standard Resistors to be calibrated  
A black and a white 18-inch plug lead  
A photocopy of the data sheet from Figure 5-25, shown on the  
last page of Section 5



### 5.2.3 Detailed Procedure

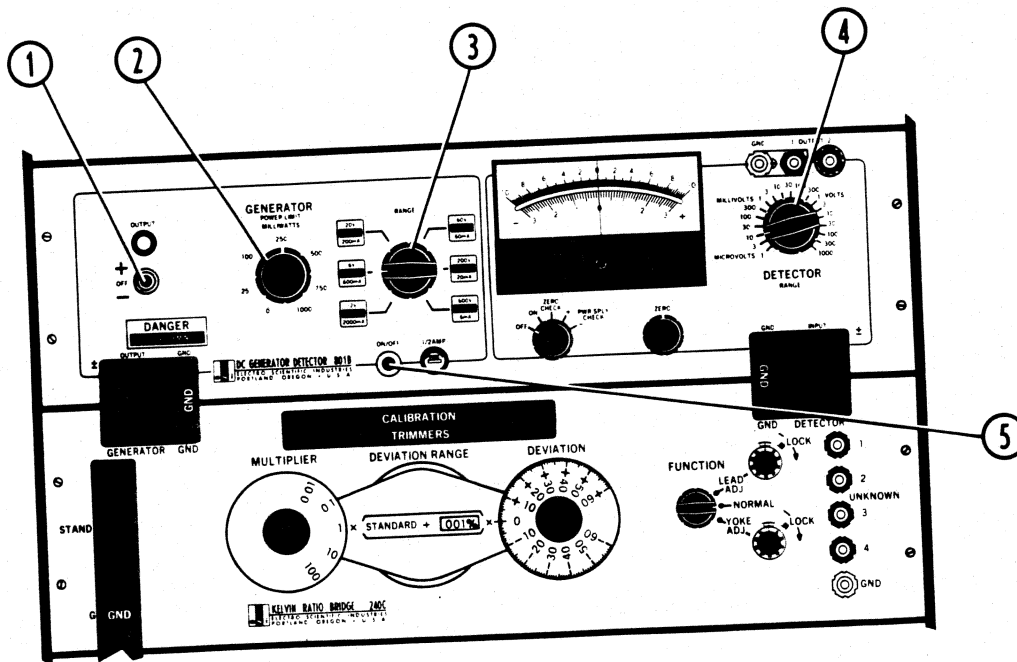

Figure 5-2. Generator-Detector Dial Settings

#### 242D GENERATOR-DETECTOR DIAL SETTINGS FOR MEASURING 10 OHM RESISTORS

- STEP 1. OUTPUT switch, set to OFF.
- STEP 2. GENERATOR POWER, set to 250 MILLIWATTS.
- STEP 3. GENERATOR RANGE switch, set to 10 ohms.
- STEP 4. DETECTOR RANGE switch, set to 10 MICROVOLTS.
- STEP 5. Press ON/OFF pushbutton to ON.

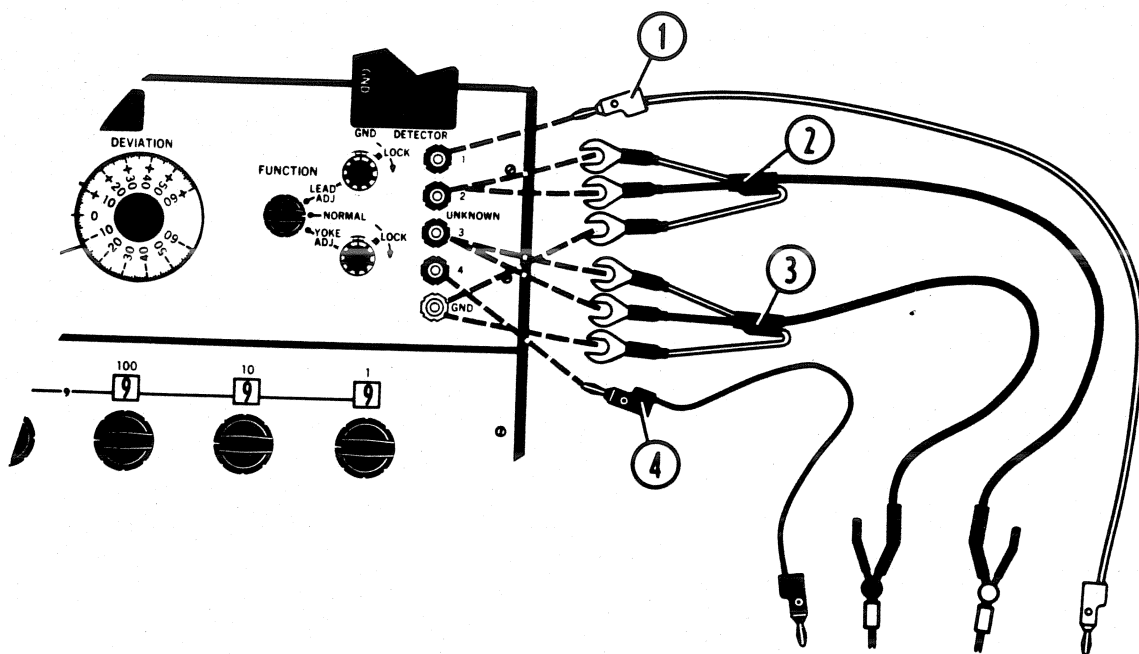

Figure 5-3. Lead Connections

#### 242D LEAD CONNECTIONS TO SR1060

- STEP 1. White 18-inch plug lead, connect one end to 242D Bridge UNKNOWN terminal 1.
- STEP 2. White KELVIN KLIP (with white hinge), connect white and black spade lugs to 242D Bridge UNKNOWN terminal 2. Connect the Ground lead from the white KELVIN KLIP to 242D Bridge UNKNOWN GND terminal.
- STEP 3. Black KELVIN KLIP (with black hinge), connect the white and black spade lugs to 242D Bridge UNKNOWN terminal 3. Connect the Ground lead from the black KELVIN KLIP to 242D Bridge UNKNOWN GND terminal.
- STEP 4. Black 18-inch plug lead, connect one end to 242D Bridge UNKNOWN terminal 4.

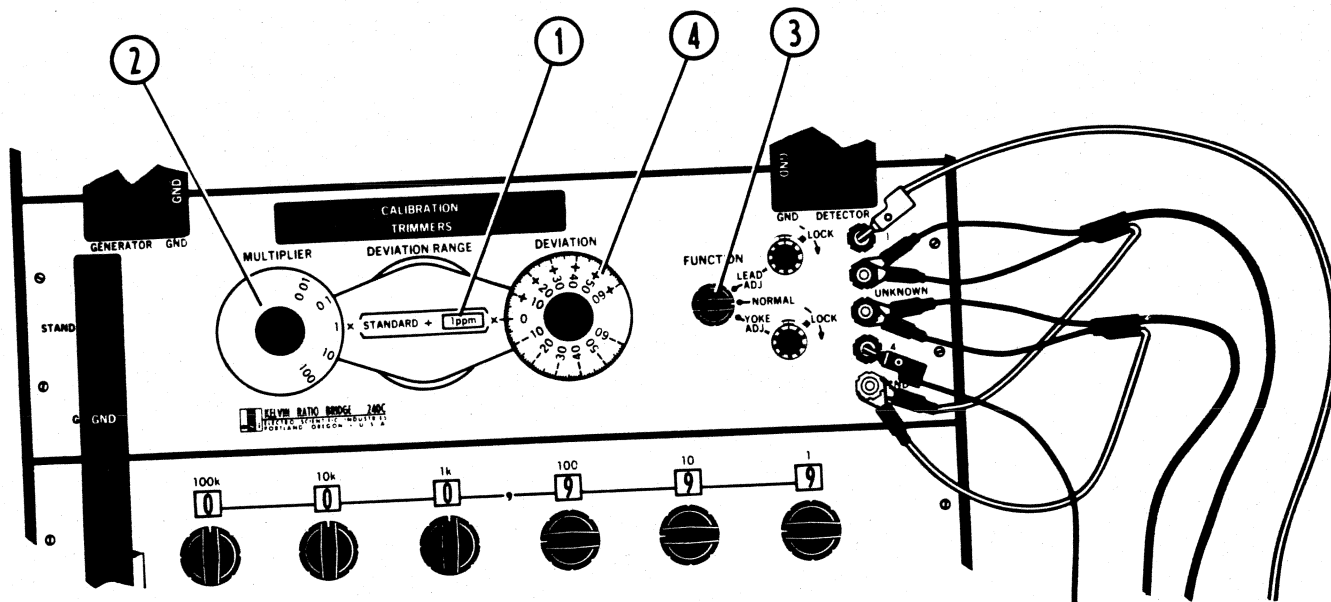

Figure 5-4. Bridge Dial Settings

242D BRIDGE DIAL SETTINGS  
FOR MEASURING WITHIN A  $\pm 60$  PPM RANGE

- STEP 1. Directly in the center of the bridge is the DEVIATION RANGE dial. Set this dial to 1 ppm. The 1 ppm will appear in the small window on the right side of the dial mask.
- STEP 2. To the left of this dial is the STANDARD MULTIPLIER dial. Set this dial to 1.
- STEP 3. FUNCTION switch, set to NORMAL.
- STEP 4. 10 ohm standard resistor, find its certified value. Subtract the nominal value (10 ohms in this case) from the certified value. Divide the result by the nominal value (10) and multiply it by one million. This is the certified deviation in ppm, which is positive if the certified value is above the nominal value, negative if below. On the bridge DEVIATION dial, set the certified deviation. On the data sheet, record the certified deviation on the first (Certified Value) line.

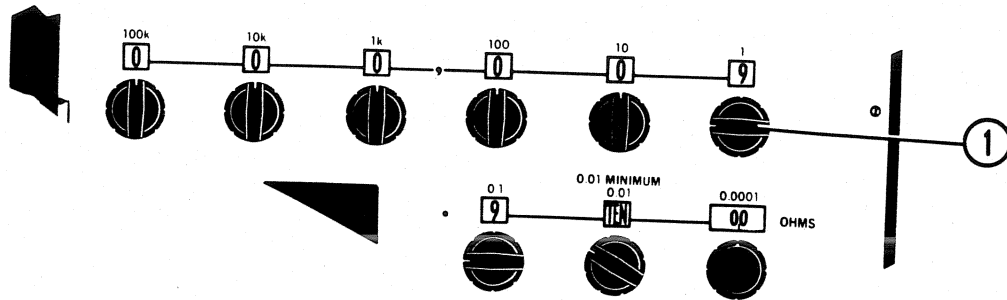
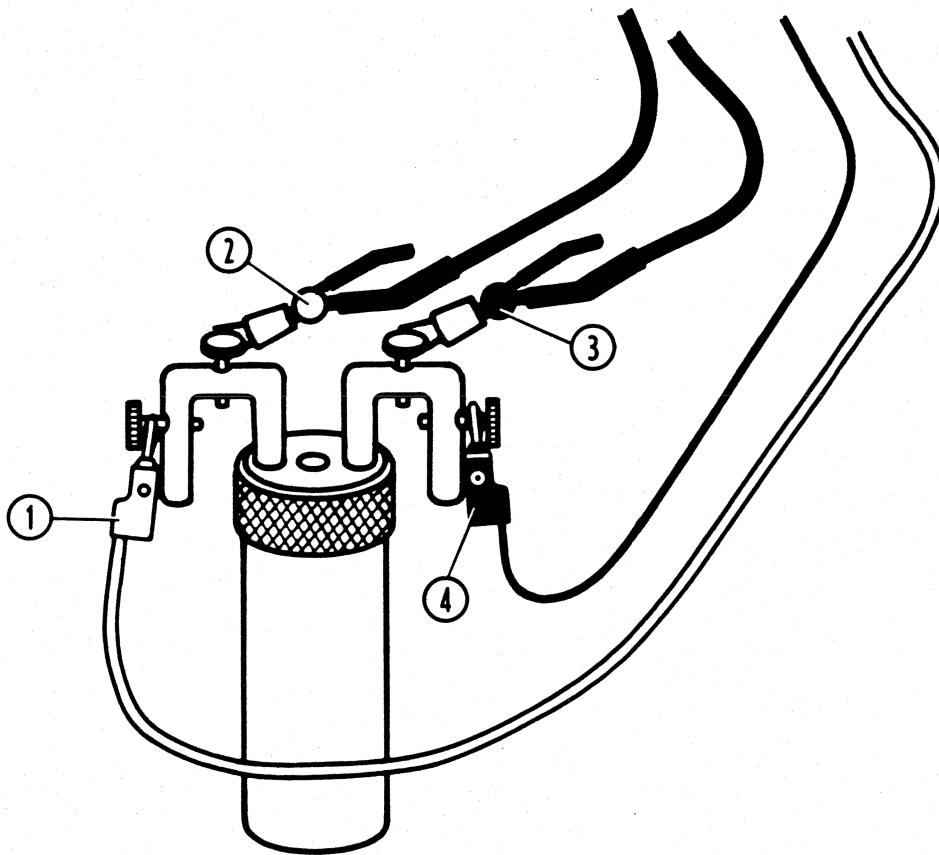

Figure 5-5. Resistance Standard Dial Setting

242D RESISTANCE STANDARD DIAL SETTING

- STEP 1. RESISTANCE STANDARD dials, set to 9.9 TEN 00 for ten ohms. Set all other dials on the RESISTANCE STANDARD to 0.



**Figure 5-6. 10 ohm Standard Resistor Connections**

10 OHM STANDARD RESISTOR CONNECTION

- STEP 1. White plug lead, connect to the standard resistor, outer screw on the first arm.
- STEP 2. White KELVIN KLIP, connect to the standard resistor, inner screw on the arm used in STEP 1.
- STEP 3. Black KELVIN KLIP, connect to the standard resistor, inner screw on the other arm.
- STEP 4. Black plug lead, connect to the standard resistor, outer screw on the arm used in STEP 3.

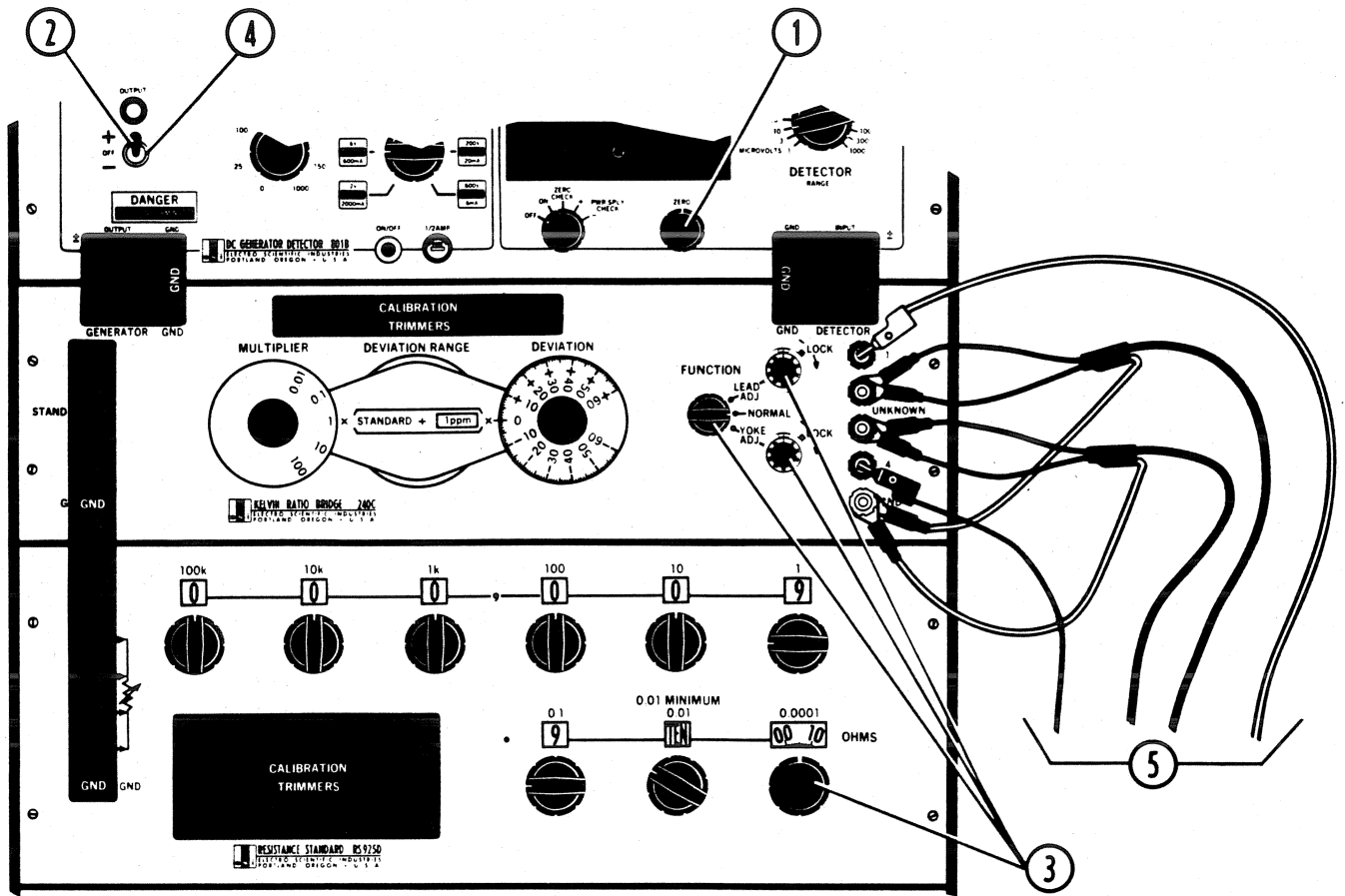

Figure 5-7. System Calibration at 10 ohms

242D SYSTEM CALIBRATION AT 10 OHMS

STEP 1. 242D ZERO control, adjust for meter zero.

STEP 2. OUTPUT switch, set to plus position.

STEP 3. LEAD ADJ, YOKE ADJ, and RESISTANCE STANDARD, adjust for proper null as follows:

- A. Set the FUNCTION switch to NORMAL. If the meter pointer is offscale, change the DETECTOR RANGE to reduce sensitivity. Return to 10 MICROVOLT position for final null balance.
- B. Turn the FUNCTION switch to LEAD ADJ and turn the LEAD ADJ knob for a meter null.
- C. Turn the FUNCTION switch to NORMAL and adjust the RESISTANCE STANDARD for a meter null.
- D. Turn the FUNCTION switch to YOKE ADJ and turn the YOKE ADJ knob for a meter null.
- E. Turn the FUNCTION switch to NORMAL and adjust the RESISTANCE STANDARD for a meter null.
- F. Repeat this sequence (B, C, D, and E) until all three FUNCTION positions give a meter null (with the DETECTOR RANGE set on 10 MICROVOLT and with both generator polarities) with no further adjustments.

STEP 4. The 242D is now calibrated at 10 ohms to the 10 ohm standard resistor. Turn the OUTPUT switch OFF.

STEP 5. Remove all leads from the 10 ohm standard resistor.

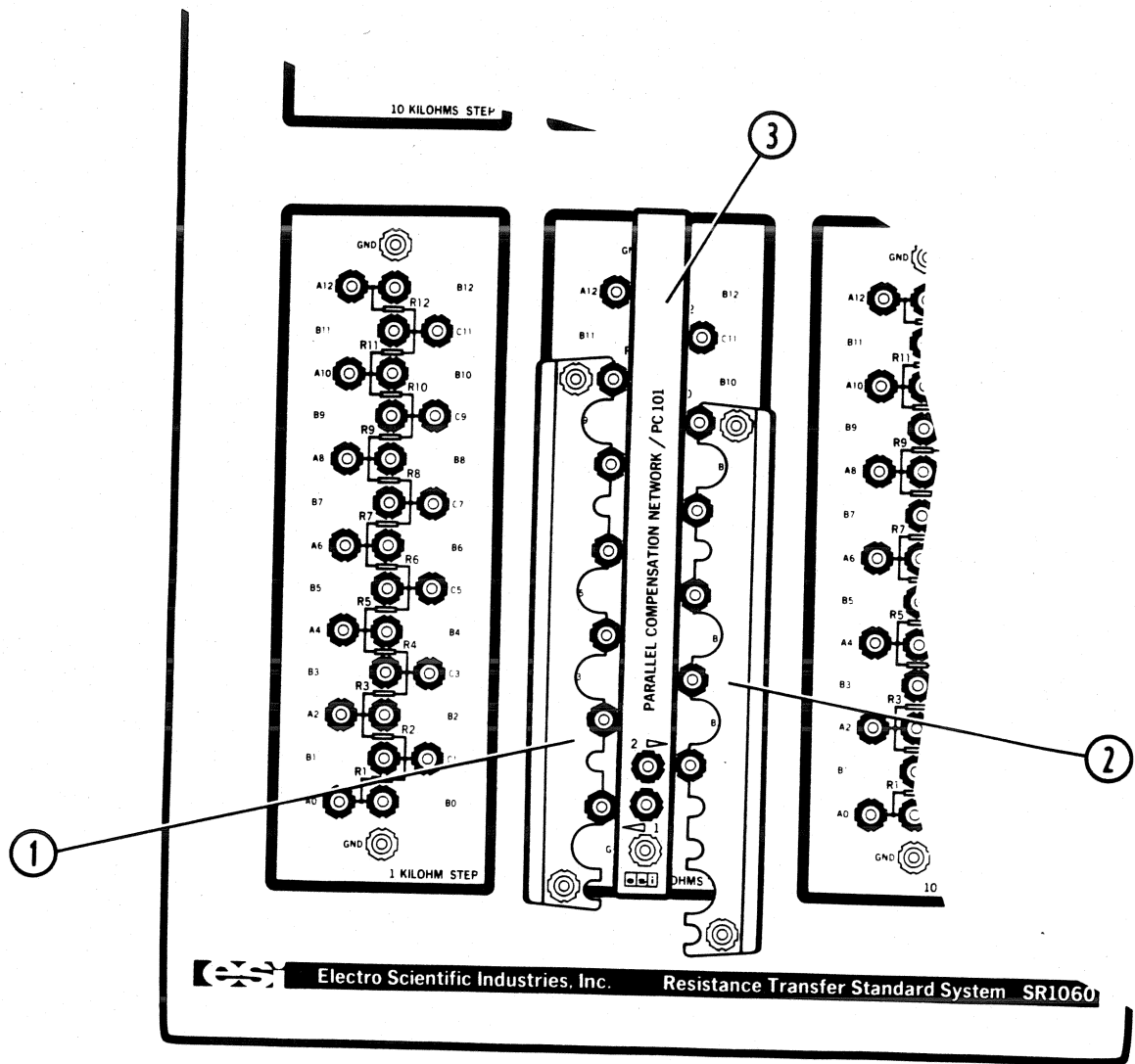

Figure 5-8. 100 ohm Resistor Bank Calibration at 10 ohms



## 100 OHM RESISTOR BANK CALIBRATION AT 10 OHMS

### Shorting Bar and Network Connections:

- STEP 1. 100 ohm-per-step SR1060 Resistor Bank, arrange so that it faces you. Hold a gold-plated Shorting Bar beside the row of binding posts on your left so that its end binding post is opposite A10. Connect the Shorting Bar at A10, A8, A6, A4, A2, and A0. Tighten these binding posts.
- STEP 2. Other Shorting Bar, hold on your right so its end binding post is opposite C9. Connect the Shorting Bar at C9, C7, C5, C3, and C1. Tighten these binding posts.
- STEP 3. PC101 Network, gold GND terminal, place above the gold GND terminal at the near end of the SR1060 Resistor Bank. Connect the PC101 Network to the center row of binding posts on the Resistor Bank.

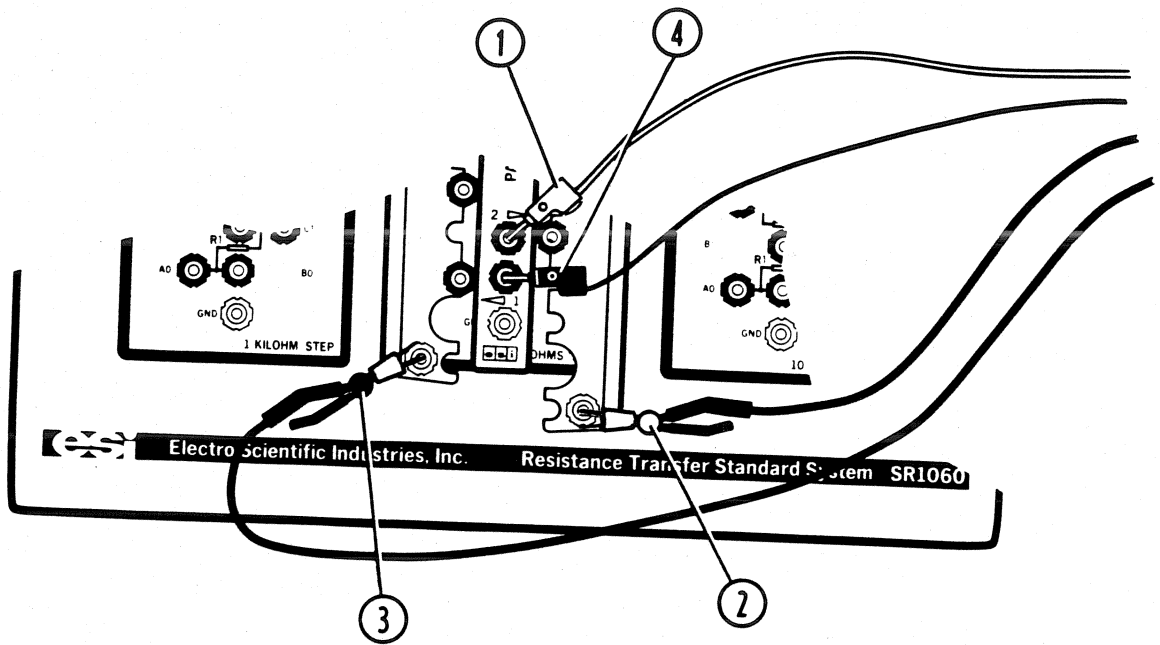

Figure 5-9. Lead Connections to the SR1060

## 242D LEAD CONNECTIONS TO THE SR1060

- STEP 1. White plug lead, connect to the PC101 terminal 2.
- STEP 2. White KELVIN KLIP, connect to the right-hand Shorting Bar binding post with one jaw inside and one outside of the binding post.
- STEP 3. Black KELVIN KLIP, connect to the left-hand Shorting Bar binding post.
- STEP 4. Black plug lead, connect to the PC101 terminal 1.

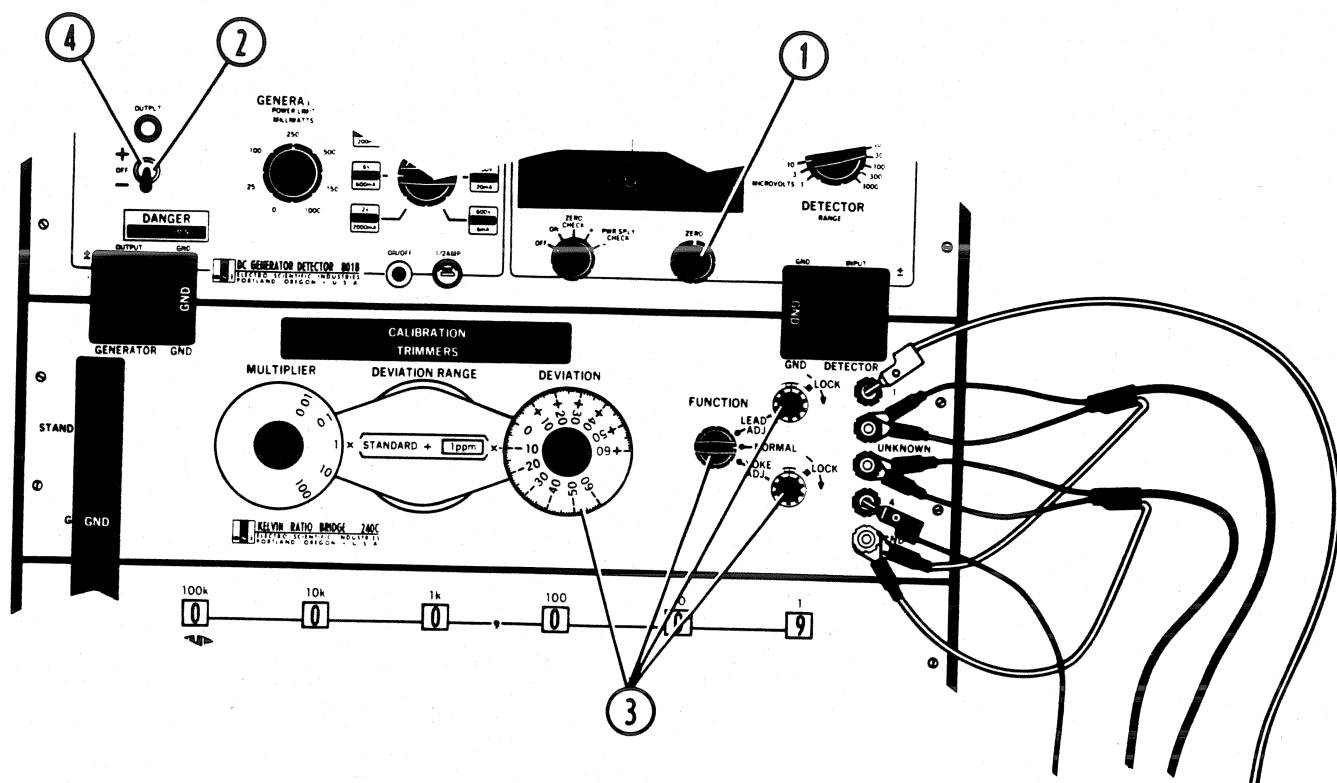

Figure 5-10. Deviation Measurement

SR1060 DEVIATION MEASUREMENT  
FOR AVERAGE DEVIATION OF FIRST 10 RESISTORS

STEP 1. 242D ZERO Control, adjust for meter zero.

STEP 2. OUTPUT switch, set to minus position.

STEP 3. LEAD ADJ, YOKE ADJ, and DEVIATION knobs, adjust for proper null as follows:

- A. Set the FUNCTION switch to NORMAL. Adjust the DEVIATION knob to 0. If the meter pointer is offscale, change the DETECTOR RANGE to reduce sensitivity. Return to 10 MICROVOLT position for final null balance.
- B. Turn the FUNCTION switch to LEAD ADJ and turn the LEAD ADJ knob for a meter null.
- C. Turn the FUNCTION switch to NORMAL and adjust the DEVIATION knob for a meter null.
- D. Turn the FUNCTION switch to YOKE ADJ and turn the YOKE ADJ knob for a meter null.
- E. Turn the FUNCTION switch to NORMAL and adjust the DEVIATION knob for a meter null.
- F. Repeat this sequence (B, C, D, and E) until all three FUNCTION positions give a meter null (with the DETECTOR RANGE set on 10 MICROVOLT and with both generator polarities) with no further adjustments.

STEP 4. Output switch OFF; record the DEVIATION dial reading on the data sheet. This is  $\Delta_{AV}$ ; the deviation of ten 100 ohm resistors in parallel from the calibrated 10 ohm value of the 242D System.

STEP 5. Remove all leads from the SR1060 Shorting Bars and Network.

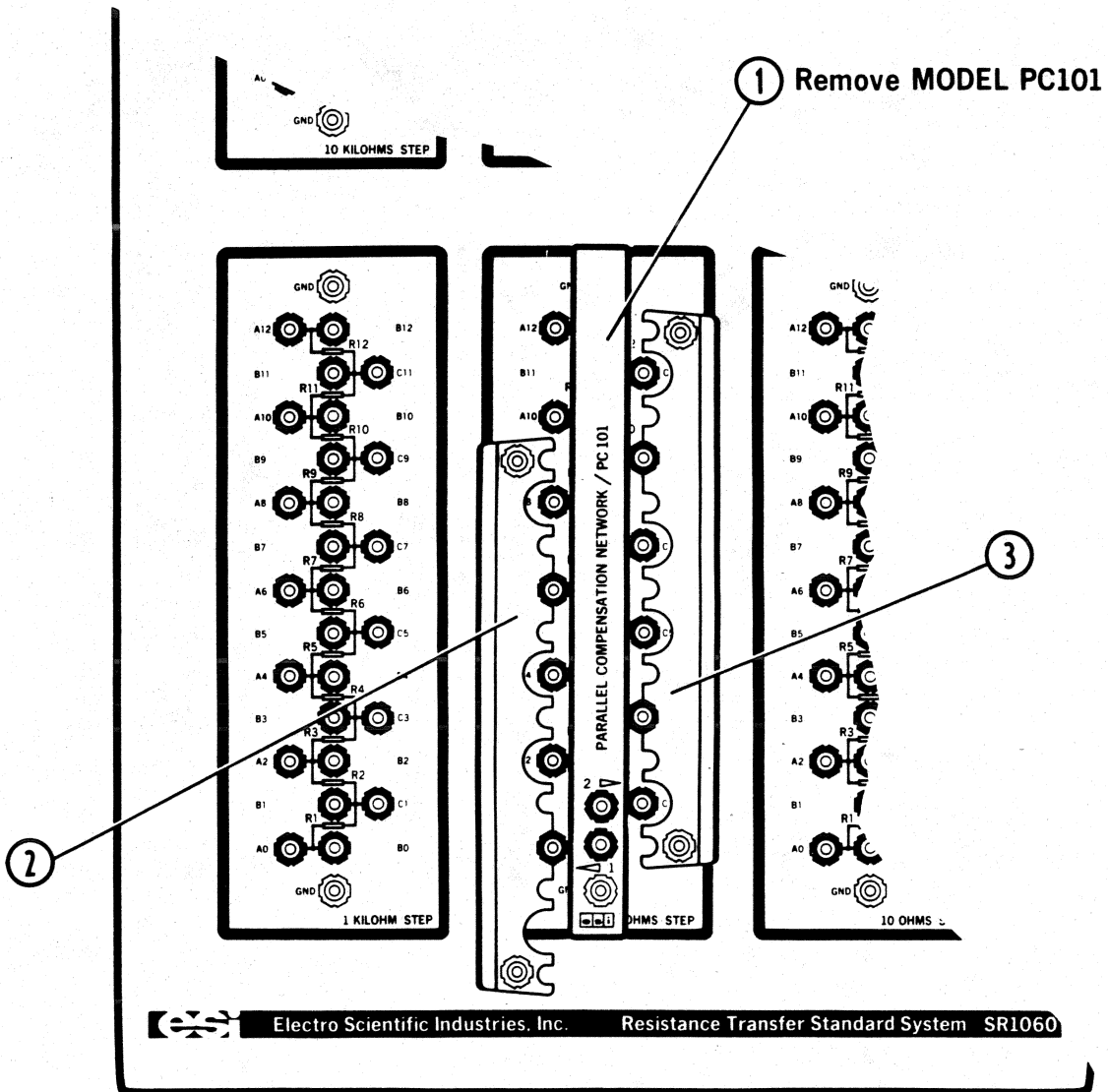
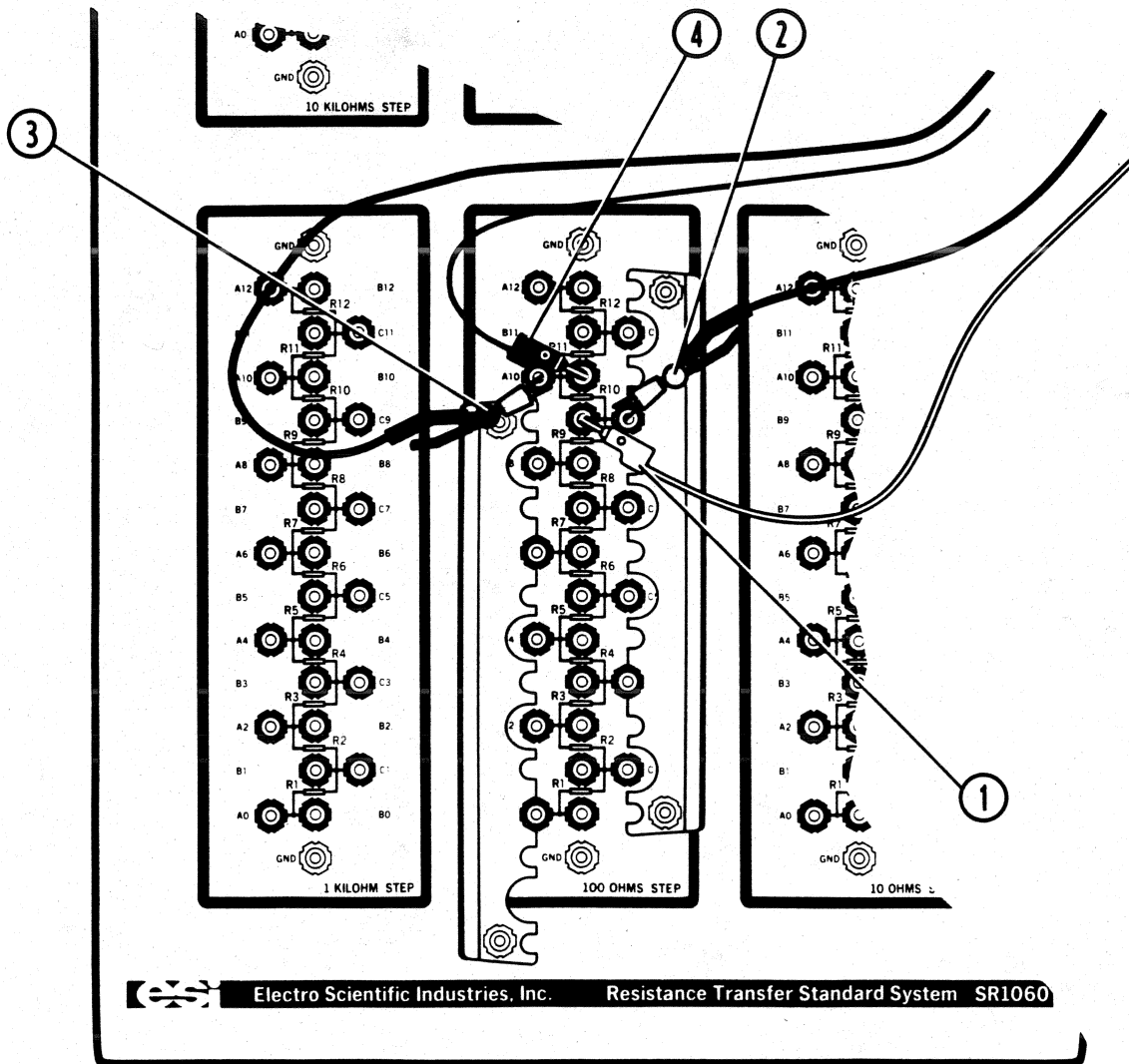

Figure 5-11. Calibration at 100 ohms

## SERIES-PARALLEL CONNECTION OF 100 OHM-PER STEP RESISTOR BANK

### Shorting Bar Connection:

- STEP 1. PC101 Network, remove from the SR1060 by grasping both ends of the Network and pulling straight up to avoid bending the banana plugs.
- STEP 2. Left-hand Shorting Bar, loosen the binding posts that hold it in place. With the end binding post opposite B9, connect it at A0 and A6. Tighten these binding posts.
- STEP 3. Right-hand Shorting Bar, loosen the binding posts that hold it in place. With the end Shorting Bar binding posts held opposite B0 and B12, connect at C3 and C9. Tighten these binding posts.



**Figure 5-12. Lead Connections**

**SR1060 LEAD CONNECTION FOR MEASURING R10**

- STEP 1. White plug lead, connect to terminal B9.
- STEP 2. White KELVIN KLIP, connect to terminal C9.
- STEP 3. Black KELVIN KLIP, connect to the terminal A10.
- STEP 4. Black plug lead, connect to SR1060 terminal B10.



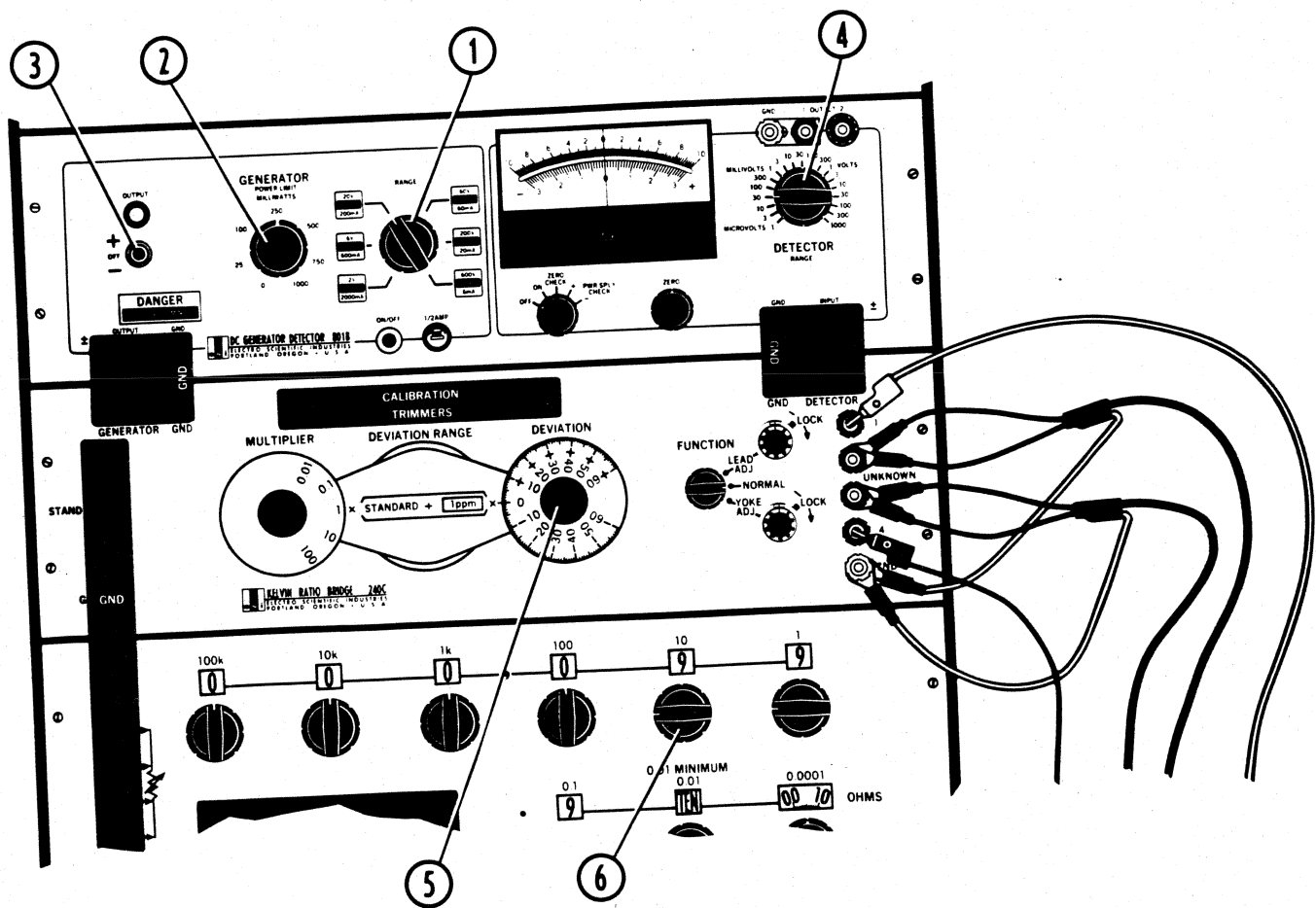

Figure 5-13. System Dial Settings

242D SYSTEM DIAL SETTINGS FOR MEASURING 100 OHM RESISTORS

- STEP 1. GENERATOR RANGE, set to 100 ohms.
- STEP 2. GENERATOR POWER, set to 250 MILLIWATTS.
- STEP 3. OUTPUT switch, set to OFF.
- STEP 4. DETECTOR RANGE switch, set to 30 MICROVOLTS.
- STEP 5. Bridge DEVIATION dial, set to 0.
- STEP 6. RESISTANCE STANDARD 10 dial, rotate counter clockwise to 9.

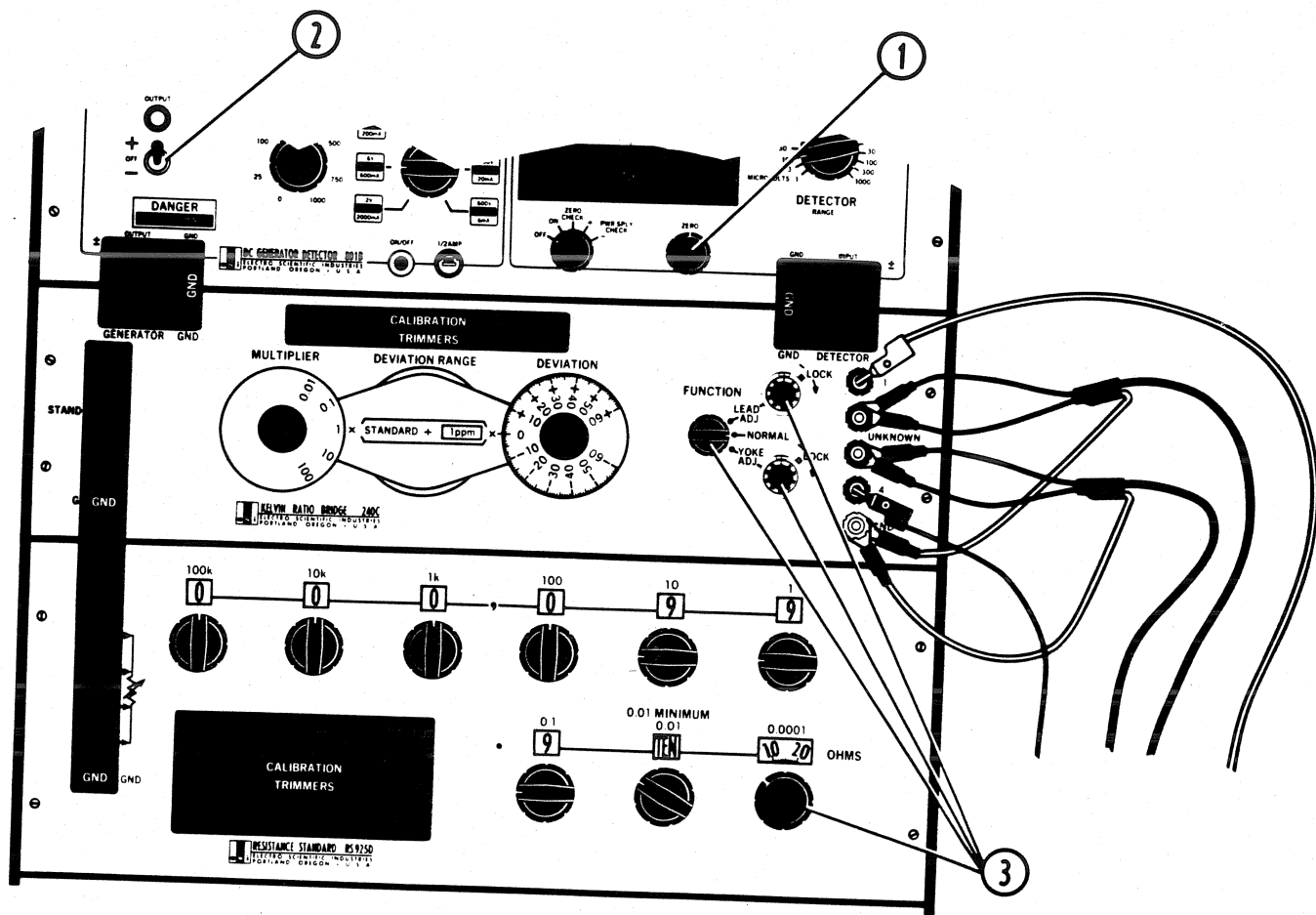

Figure 5-14. Measurement of Resistor R10

242D MEASUREMENT OF 100 OHM-PER-STEP SR1060 RESISTOR R10

- STEP 1. 242D ZERO control, adjust for meter zero.
- STEP 2. OUTPUT switch, set to plus position.
- STEP 3. LEAD ADJ, YOKE ADJ, and RESISTANCE STANDARD, adjust for meter null as described earlier.
- STEP 4. OUTPUT switch OFF.

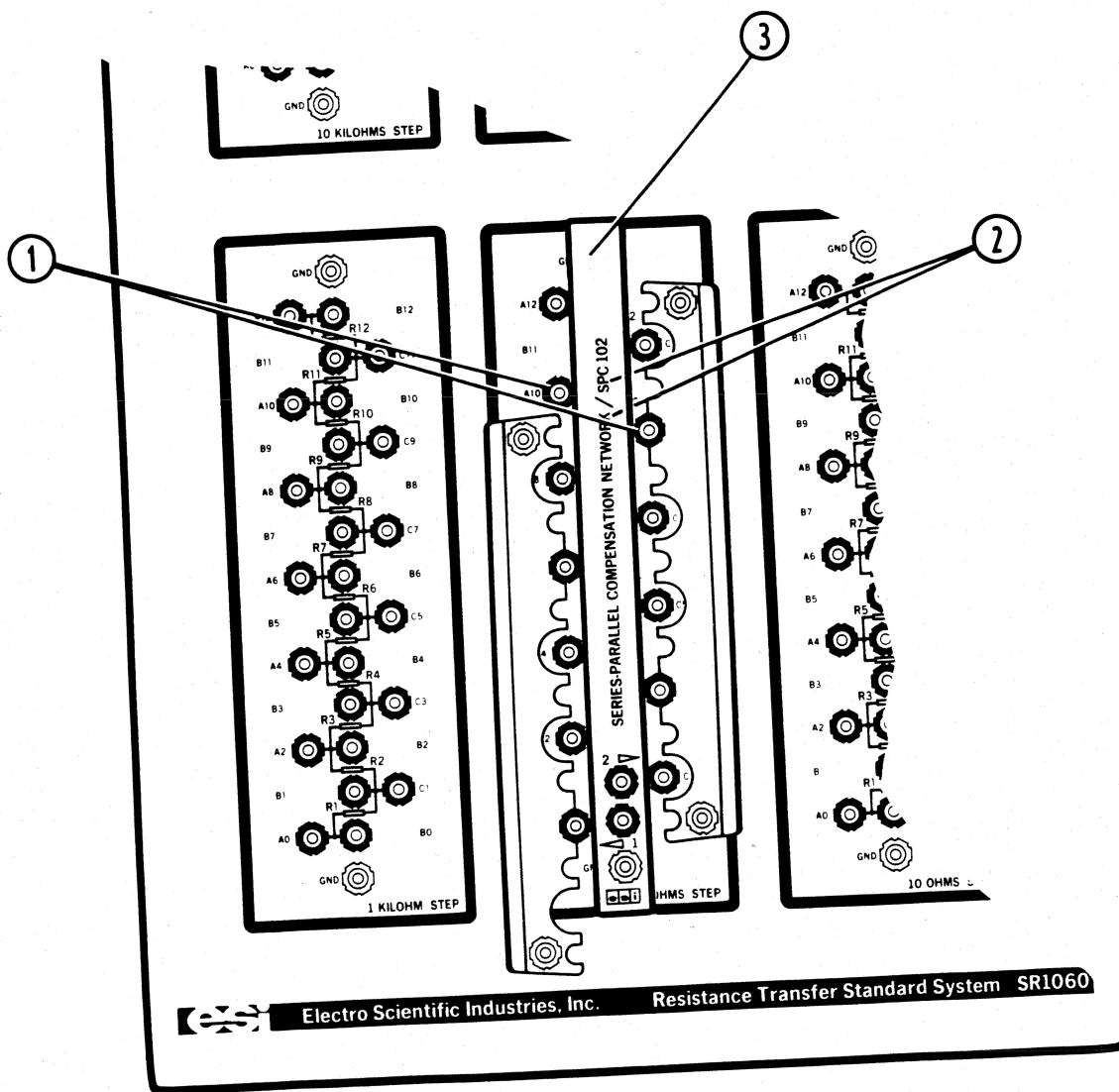

Figure 5-15. Lead and Network Connections

SR1060 LEAD AND NETWORK CONNECTIONS

STEP 1. KELVIN KLIPS, remove from terminals A10 and C9.

STEP 2. Plug leads, remove from terminals B10 and B9.

STEP 3. SPC102 Network, pick up. The GND terminal on the Network will connect to the GND terminal at the near end of the SR1060. Connect SPC102 Network to center row of terminals on the SR1060.

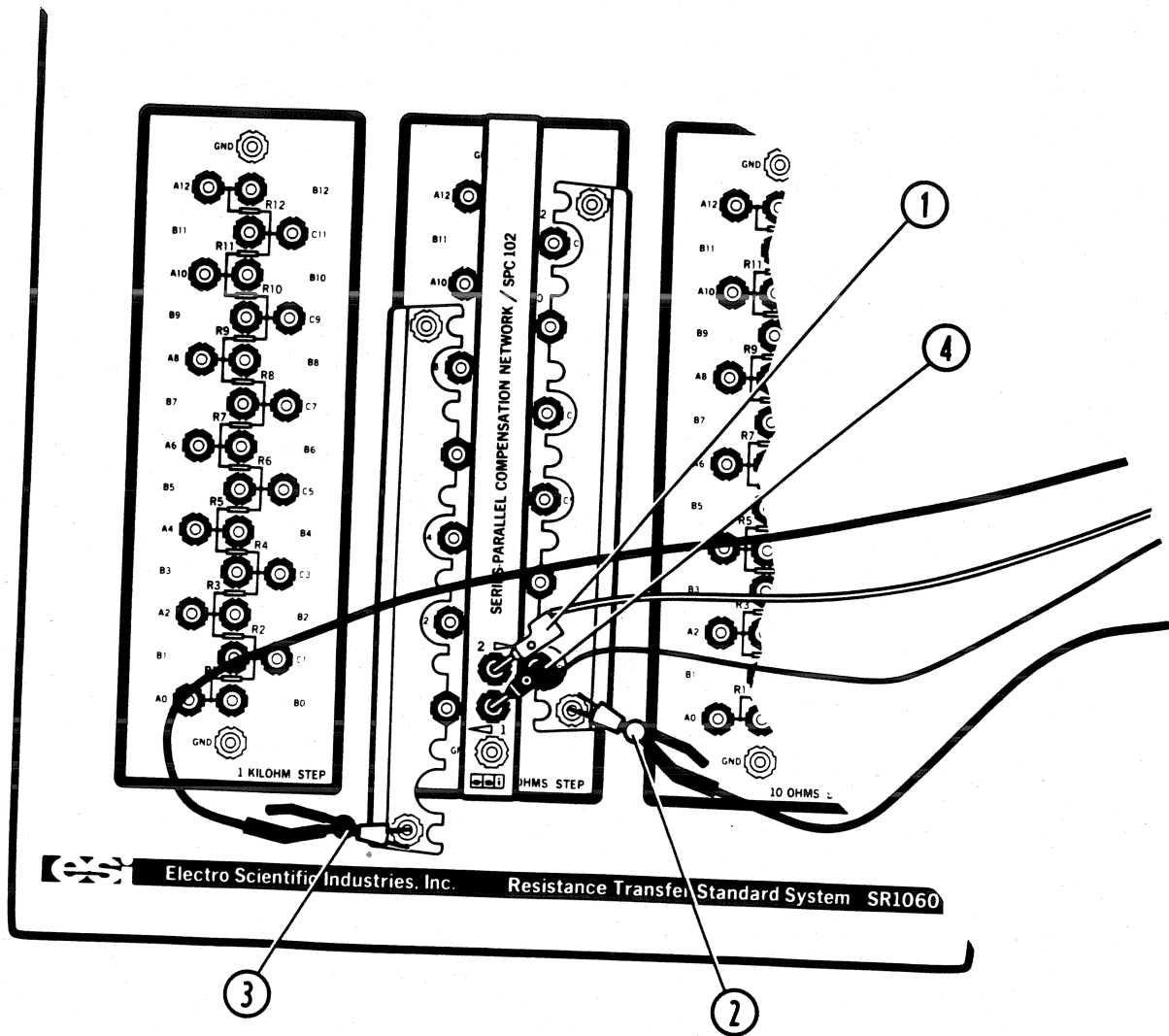

Figure 5-16. Lead Connections

#### SR1060 LEAD CONNECTIONS

- STEP 1. White plug lead, connect to the SPC102 Network terminal 2.
- STEP 2. White KELVIN KLIP, connect to the right-hand Shorting Bar binding post.
- STEP 3. Black KELVIN KLIP, connect to the left-hand Shorting Bar binding post.
- STEP 4. Black plug lead, connect to the SPC102 Network terminal 1.

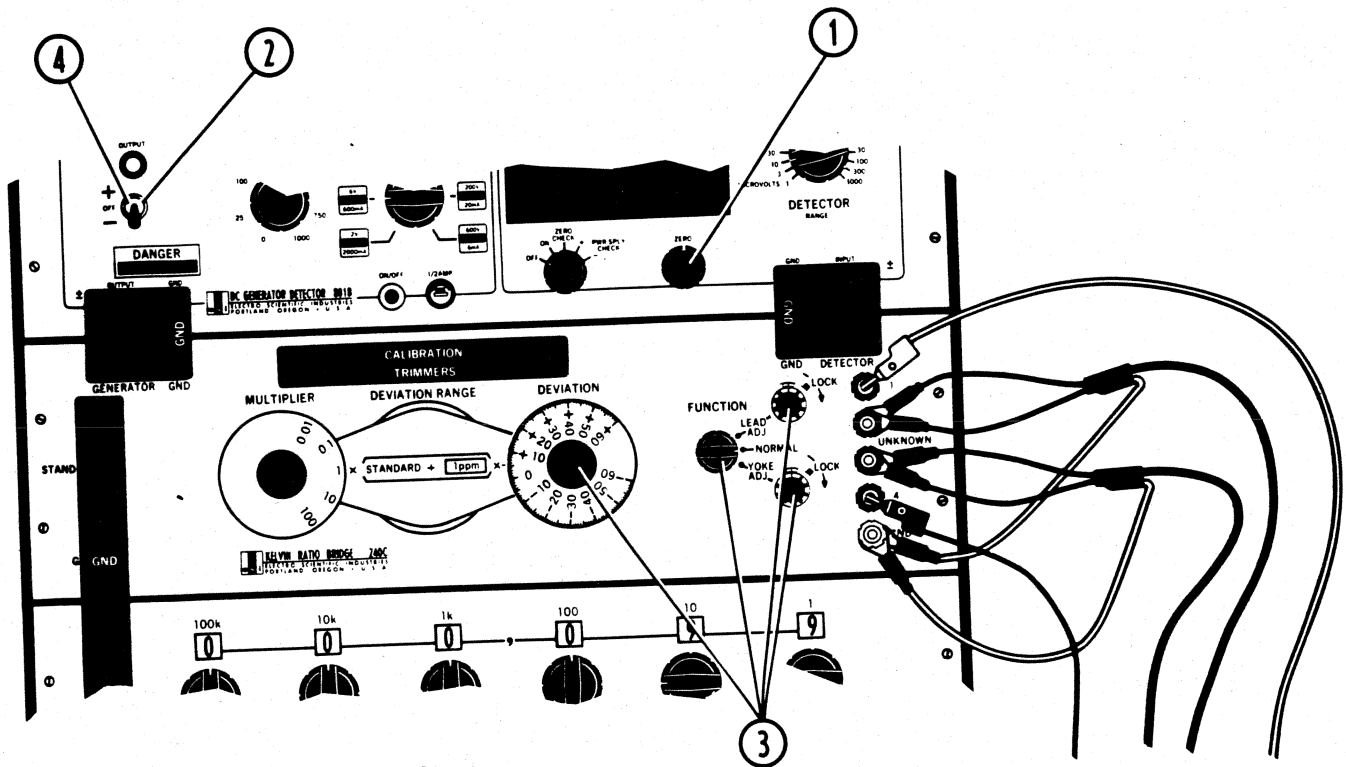

Figure 5-17. Series-Parallel Deviation from R10

SR1060 SERIES-PARALLEL DEVIATION FROM R10

- STEP 1. 242D ZERO Control, adjust for meter zero.
- STEP 2. OUTPUT switch, set to minus position.
- STEP 3. LEAD ADJ, YOKE ADJ, and DEVIATION dial, adjust for meter null as described earlier.
- STEP 4. OUTPUT switch OFF.
- STEP 5. Record the DEVIATION reading on the Data Sheet as  $\Delta_D$ . This is the deviation of the series-parallel combination of the nine 100 ohm resistors from R10. Calculate  $\Delta_{sp}$  on the Data Sheet, using the printed equation.  $\Delta_{sp}$  is the deviation of the series-parallel connection from 10 times the nominal value of the 10 ohm Standard relative to its certificate.

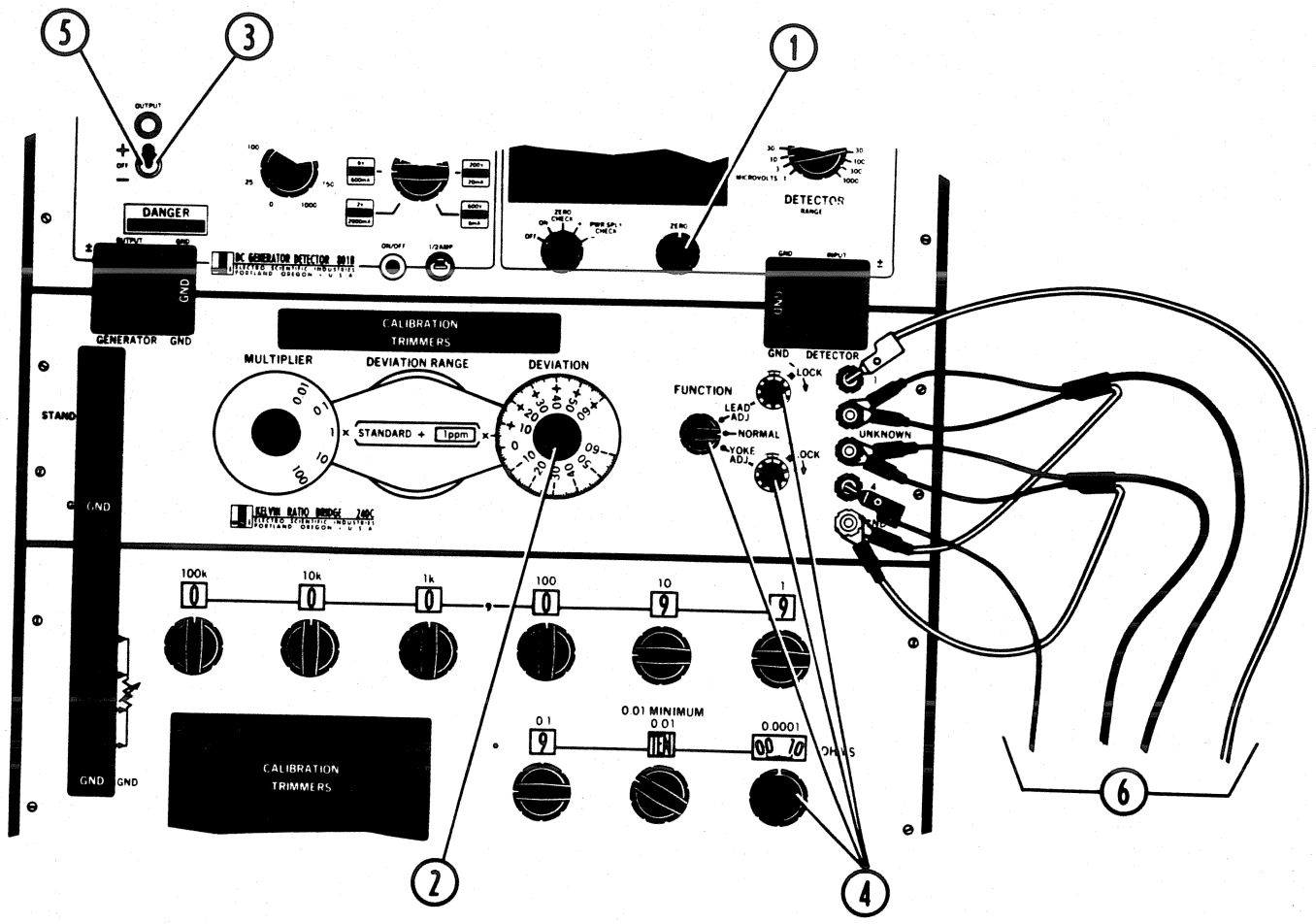

Figure 5-18. Bridge Calibration at 100 ohms

## 242D BRIDGE CALIBRATION AT 100 OHMS

- STEP 1. 242D ZERO control, adjust for meter zero.
- STEP 2. Bridge DEVIATION dial, set to  $\Delta_{sp}$ .
- STEP 3. OUTPUT switch, set to plus position.
- STEP 4. LEAD ADJ, YOKE ADJ, and RESISTANCE STANDARD, adjust for meter null as described earlier.
- STEP 5. OUTPUT switch OFF. The 242D Bridge is now calibrated to read 100 ohms relative to the 10 ohm standard certified accuracy.
- STEP 6. Remove all leads from the SR1060. Remove the SPC102 Compensation Network by grasping the ends of the Network and pulling straight up to avoid bending the banana plug. Remove the Shorting Bars. Finger-tighten all loose binding posts on the SR1060.

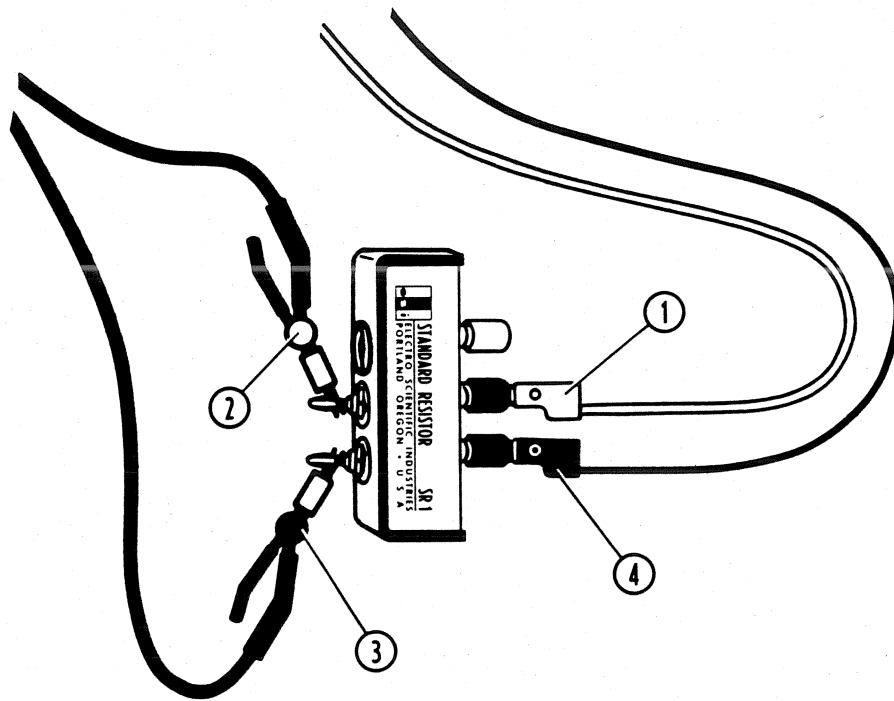

Figure 5-19. SR1 Calibration

100 OHM SR1 CALIBRATION

- STEP 1. White plug lead, connect to terminal 1 on top of the 100 ohm SR1.
- STEP 2. White KELVIN KLIP, connect to the banana plug on the bottom of terminal 1.
- STEP 3. Black KELVIN KLIP, connect to the banana plug on the bottom of terminal 2.
- STEP 4. Black plug lead, connect to terminal 2 on top.



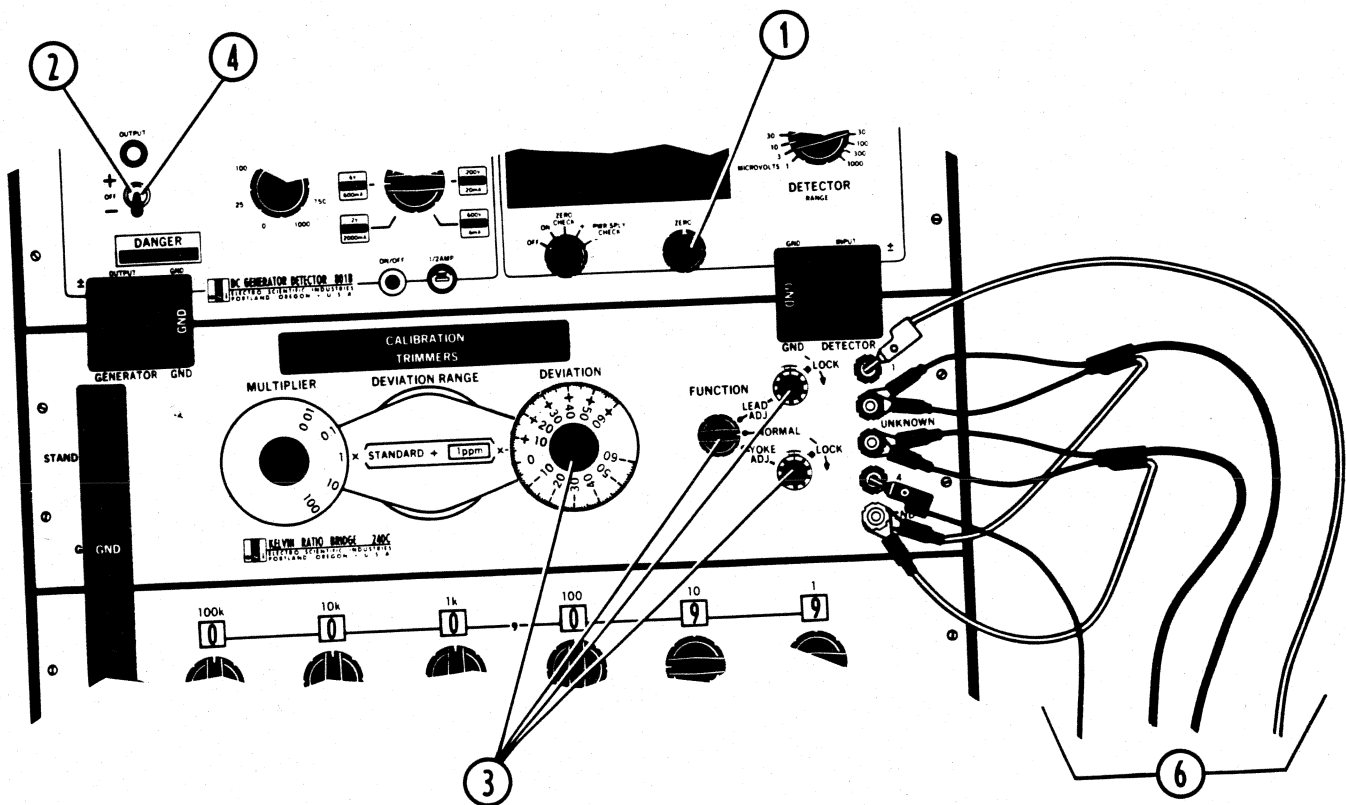

Figure 5-20. Calibration of 100 ohm SR1

### 242D CALIBRATION OF 100 OHM SR1

- STEP 1. 242D ZERO control, adjust for meter zero.
- STEP 2. OUTPUT switch, set to minus position.
- STEP 3. LEAD ADJ, YOKE ADJ, and DEVIATION, adjust for meter null as described earlier.
- STEP 4. OUTPUT switch OFF.
- STEP 5. Record the DEVIATION dial reading on the Data Sheet on the fifth (100 ohm CALIBRATED VALUE) line. This is the deviation of the 100 ohm SR1 Standard Resistor from its nominal value relative to the certified deviation of the 10 ohm Standard within the accuracy of the transfer measurement.
- STEP 6. Remove all leads from the 100 ohm SR1.

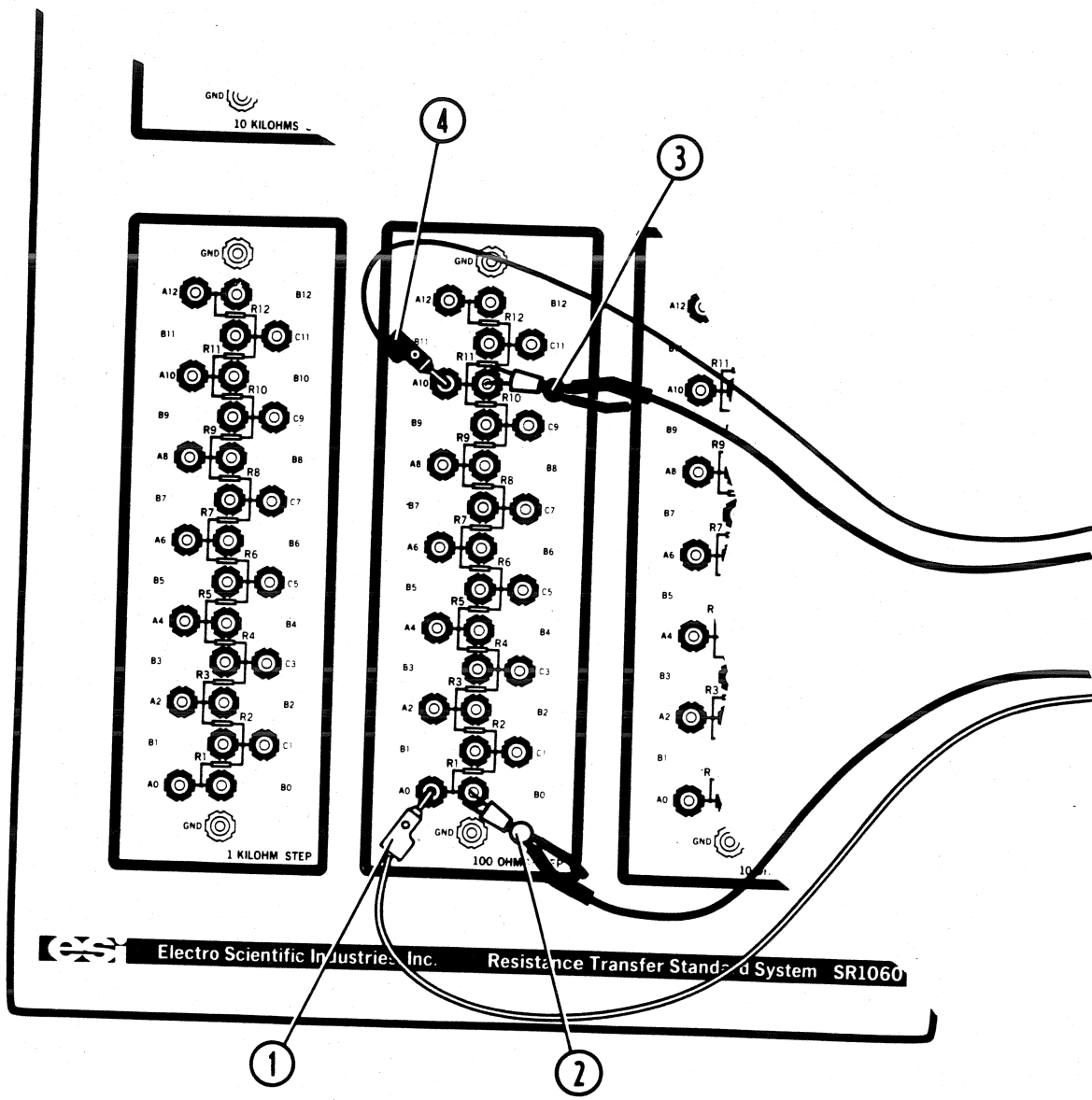

Figure 5-21. Bridge Calibration at 1 kilohm

242D BRIDGE CALIBRATION AT 1 KILOHM

STEP 1. White plug lead, connect to terminal A0.

STEP 2. White KELVIN KLIP, connect to terminal B0.

STEP 3. Black KELVIN KLIP, connect to terminal B10.

STEP 4. Black plug lead, connect to terminal A10.

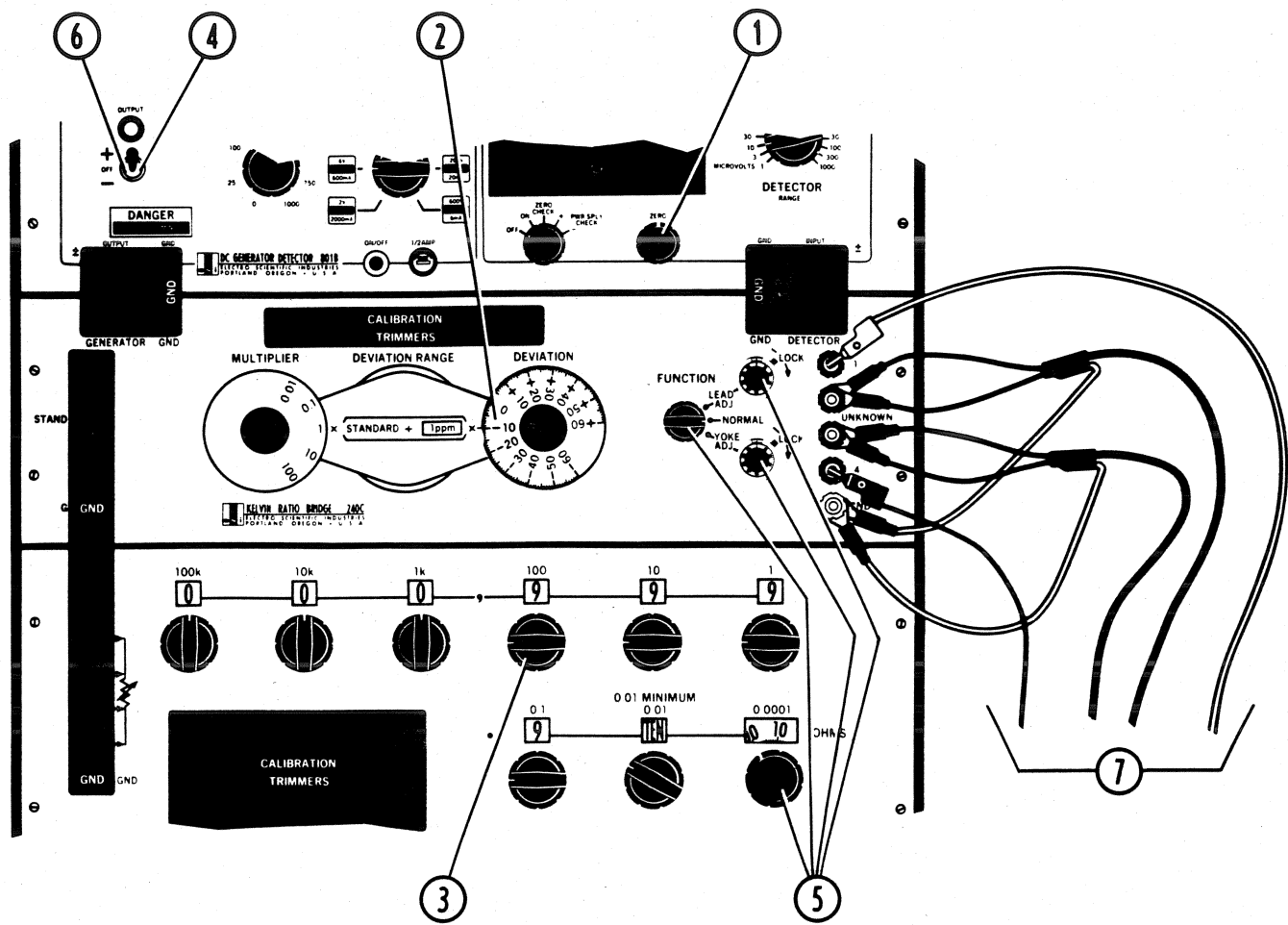

Figure 5-22. Bridge Calibration at 1 kilohm

## 242D BRIDGE CALIBRATION AT 1 KILOHM

- STEP 1. 242D ZERO control, adjust for meter zero.
- STEP 2. Bridge DEVIATION dial, set to  $\Delta_{AV}$ .
- STEP 3. RESISTANCE STANDARD 100 dial, rotate counter-clockwise to 9.
- STEP 4. OUTPUT switch, set to plus position.
- STEP 5. LEAD ADJ, YOKE ADJ, and RESISTANCE STANDARD, adjust for meter null as described earlier.
- STEP 6. OUTPUT switch OFF. The 242D Bridge is now calibrated to measure a 1 kilohm resistance.
- STEP 7. Remove all leads from the SR1060.

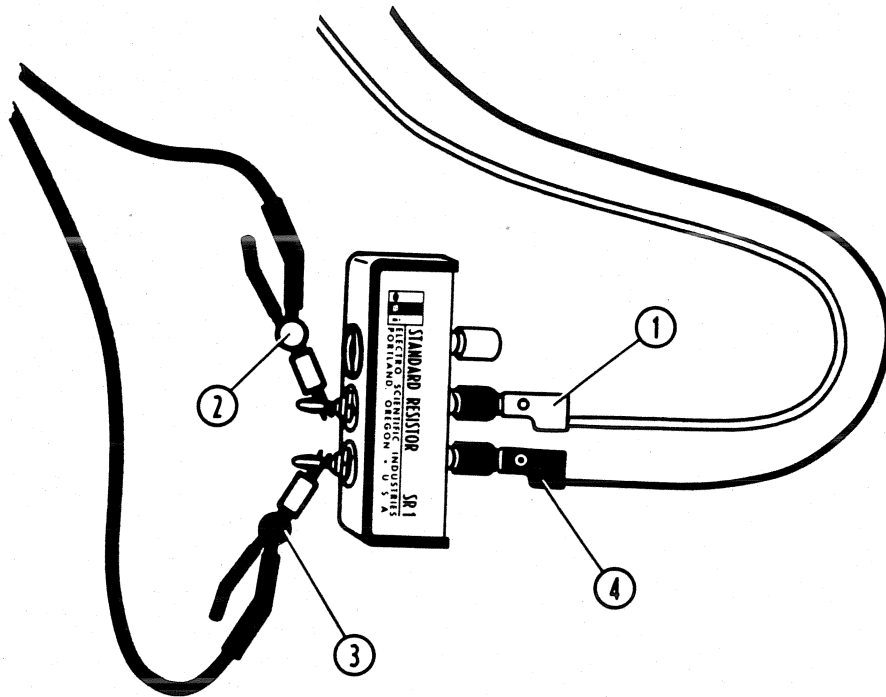

Figure 5-23. Calibration of 1 kilohm SR1

CALIBRATION OF 1 KILOHM SR1 STANDARD RESISTOR

- STEP 1. White plug lead, connect to 1 kilohm SR1, terminal 1 on top.
- STEP 2. White KELVIN KLIP, connect to the banana plug on the bottom of terminal 1.
- STEP 3. Black KELVIN KLIP, connect to the banana plug on the bottom of terminal 2.
- STEP 4. Black plug lead, connect to terminal 2 on top.

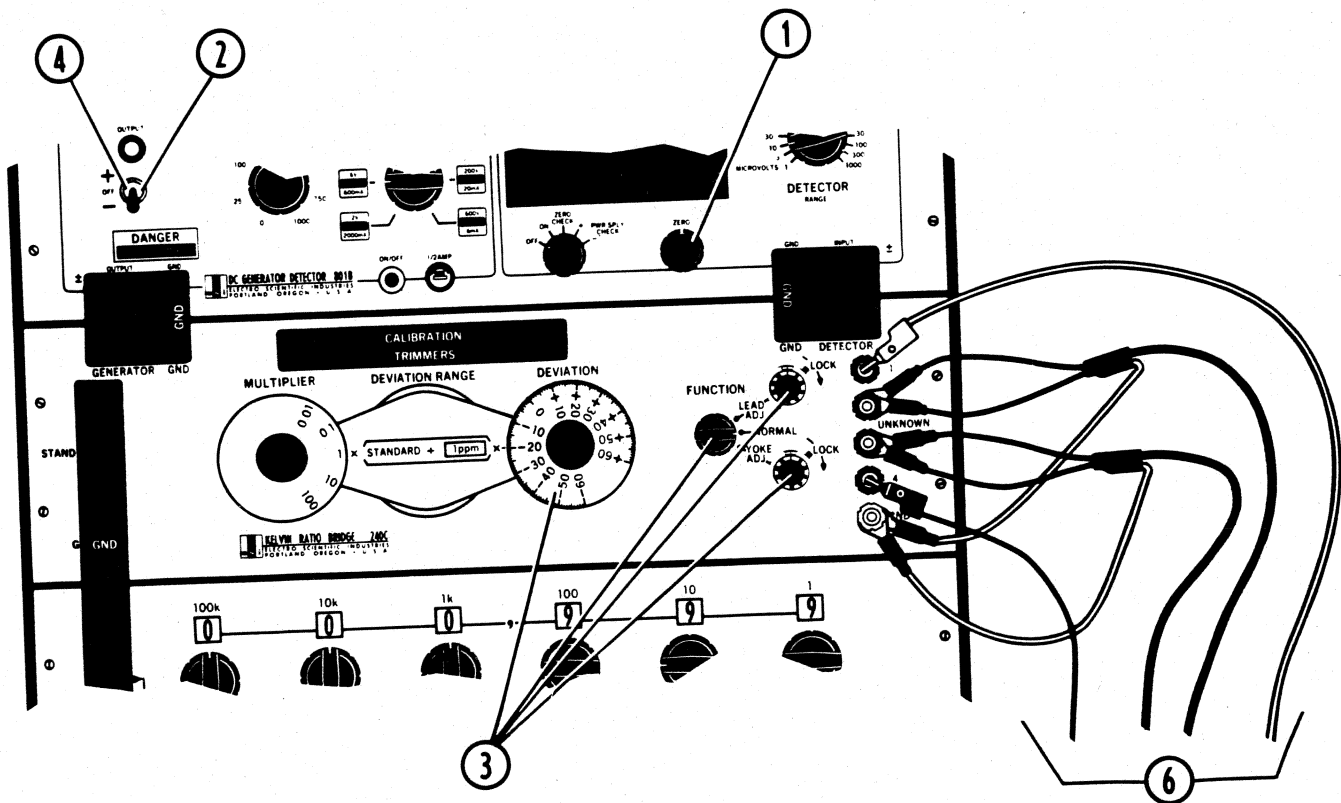

Figure 5-24. Calibration of 1 kilohm SR1

242D CALIBRATION OF 1 KILOHM SR1

- STEP 1. 242D ZERO Control, adjust for meter zero.
- STEP 2. OUTPUT switch, set to minus position.
- STEP 3. LEAD ADJ, YOKE ADJ, and DEVIATION, adjust for meter null as described earlier.
- STEP 4. OUTPUT switch OFF.
- STEP 5. Record the DEVIATION dial reading. This is the deviation of the 1 kilohm SR1 Standard Resistor from its nominal value relative to the Certified Deviation of the 10 ohm Standard within the accuracy of the transfer measurement.
- STEP 6. Remove all leads from the 1 kilohm SR1.

**MODEL SR1060**

**Resistance Transfer Standard Data Sheet**

10 ohm Standard Certified Value 10 ohms \_\_\_\_\_ ppm

SR1060 100 ohms/step PARALLEL Calibrated Value ( $\Delta AV$ ) 10 ohms \_\_\_\_\_ ppm

SR1060 100 ohms/step R10: Series-Parallel Deviation ( $\Delta D$ ) 100 ohms \_\_\_\_\_ ppm

SR1060 100 ohms/step SERIES-PARALLEL Calibration  $\Delta SP$  \_\_\_\_\_ =  $\left( (\Delta AV) \text{ _____} + \frac{(\Delta D)}{10} \text{ _____} \right)$

SR1 100 ohms CALIBRATED VALUE 100 ohms

SR1 1000 ohms CALIBRATED VALUE 1000 ohms



Electro Scientific Industries, Inc.  
 13900 N.W. Science Park Drive • Portland, Oregon 97229 • Telephone: (503) 641-4141 • Telex 4742064

**Figure 5-25. Resistance Transfer Data Sheet**



## SECTION 6

# INSTALLATION, REPAIR, AND MAINTENANCE

### 6.1 INSTALLATION

Installation of the SR1060 consists of unpacking it from its shipping container, mounting it on the optional Cart (if supplied but not already installed), filling it with oil, and performing the initial checkout. The following sections describe these steps.

#### 6.1.1 Unpacking

The SR1060, oil, and optional Cart (if used) should be removed from their shipping boxes. A careful inspection should be made to verify that no shipping damage has occurred. The binding posts should be given special attention as they are most likely to be damaged if shipping problems occur. If any shipping damage is apparent, **save all packaging material** and contact ESI promptly.

Verify that all of the appropriate items have been received as listed on the packing slip. Any discrepancies should be reported to ESI promptly.

### 6.1.2 Mounting the SR1060 on the Optional Cart

**NOTE:** If the optional Cart was **not** purchased with the SR1060, or if it was shipped already installed, skip this section.

The SR1060 is installed on the optional Cart as follows. Refer to Figure 6-1 for an illustration of the assembly. This procedure requires the following equipment:

3/16" Allen (Hex) Wrench  
7/16" Open-End Wrench or Socket and Ratchet

- STEP 1. Unscrew the nuts and washers found on each of the four 1/4-20 allen head (hex socket) screws. The 3/16" allen wrench is used on the screws; the 7/16" wrench is used on the nuts. Remove the screws from the SR1060.
  
- STEP 2. Set the SR1060 into the Cart. Verify that there are no vertical gaps between the SR1060 and Cart along both mounting surfaces.
  
- STEP 3. Insert the four allen head screws in the four mounting holes. Install and tighten the washers and nuts.

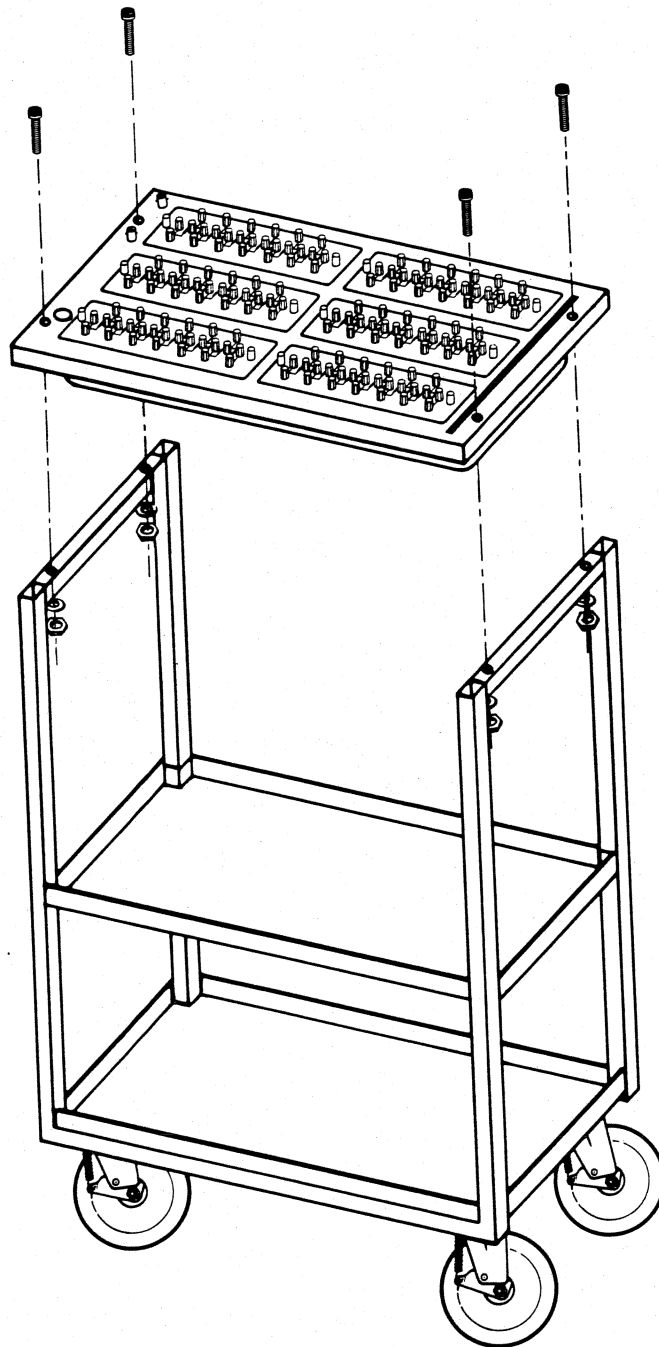

**Figure 6-1. Installing the SR1060 on the Optional Cart**

### 6.1.3 Filling the SR1060 with Oil

The next step in the installation of the SR1060 consists of filling it with oil. This is done by siphoning oil from the container into the SR1060. The procedure requires the following equipment:

Torque Wrench, readout in inch pounds or newton meters  
Allen (Hex) Wrench Drivers, 1/8 and 3/16 inch  
Socket, 1/2 inch  
Plastic Hose, 1/8 to 3/8 inch inner diameter, 3 foot length  
Cloth Rag or Paper Towels  
Table, as tall as the top surface of the SR1060, suitable for supporting the oil container

- STEP 1. Verify that all of the allen head screws are tight. 84 of these screws secure the six resistor banks (use the 3/16 inch wrench). The proper torque for these screws is 15 inch pounds (1.7 newton meters). 42 of these screws secure the upper plate to the main casting (use the 1/8 inch wrench). The proper torque for these screws is 40 inch pounds (4.5 newton meters).

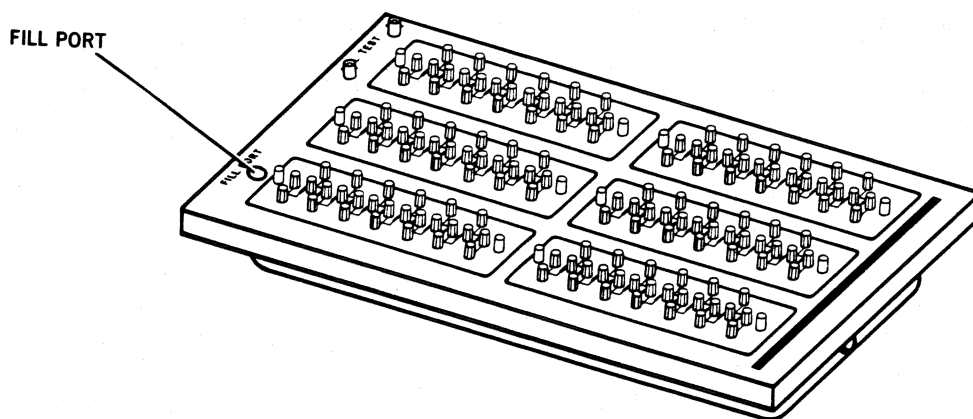

Figure 6-2. Location of the FILL PORT

- STEP 2. Using the 1/2 inch socket and torque wrench, remove the Plug that is installed in the hole labeled FILL PORT. Refer to Figure 6-2.
- STEP 3. Set the Table next to the SR1060 and place the oil container on the Table. Open the oil container.
- STEP 4. Insert the Plastic Hose into the oil, leaving about one foot of Hose outside the container. Refer to Figure 6-3a.



**THE PLASTIC HOSE USED IN THE PREVIOUS STEP MUST BE CLEAN (INSIDE AND OUT) TO AVOID CONTAMINATING THE SILICONE OIL.**

- STEP 5. Seal off the Hose by kinking it about 6 inches from the free end. Refer to Figure 6-3b.
- STEP 6. Hold the Cloth Rag around the Hose where it exits the container of Oil and pull about one foot of Hose from the container. The Rag should be used to wipe off the oil from the outside of the Hose.
- STEP 7. Place the free end of the Hose in the FILL PORT and unkink the Hose. The oil should begin to flow through the Hose into the SR1060. Refer to Figure 6-3c.
- STEP 8. When the level of the oil in the SR1060 has reached the bottom of the FILL PORT, stop the flow by kinking the Hose. There will be some air captive in the SR1060, which will allow for thermal expansion of the oil.

STEP 9. Raise the end of the Hose above the top of the oil container and unkink the Hose. Refer to Figure 6-3d. The oil in the Hose should flow back into the container. Remove the Hose from the container and wipe it clean.

STEP 10. Wipe off any oil that is on the outside of the SR1060.

STEP 11. Replace the Plug on the FILL PORT and tighten it until it is snug, about 75 inch pounds (8.5 newton meters).

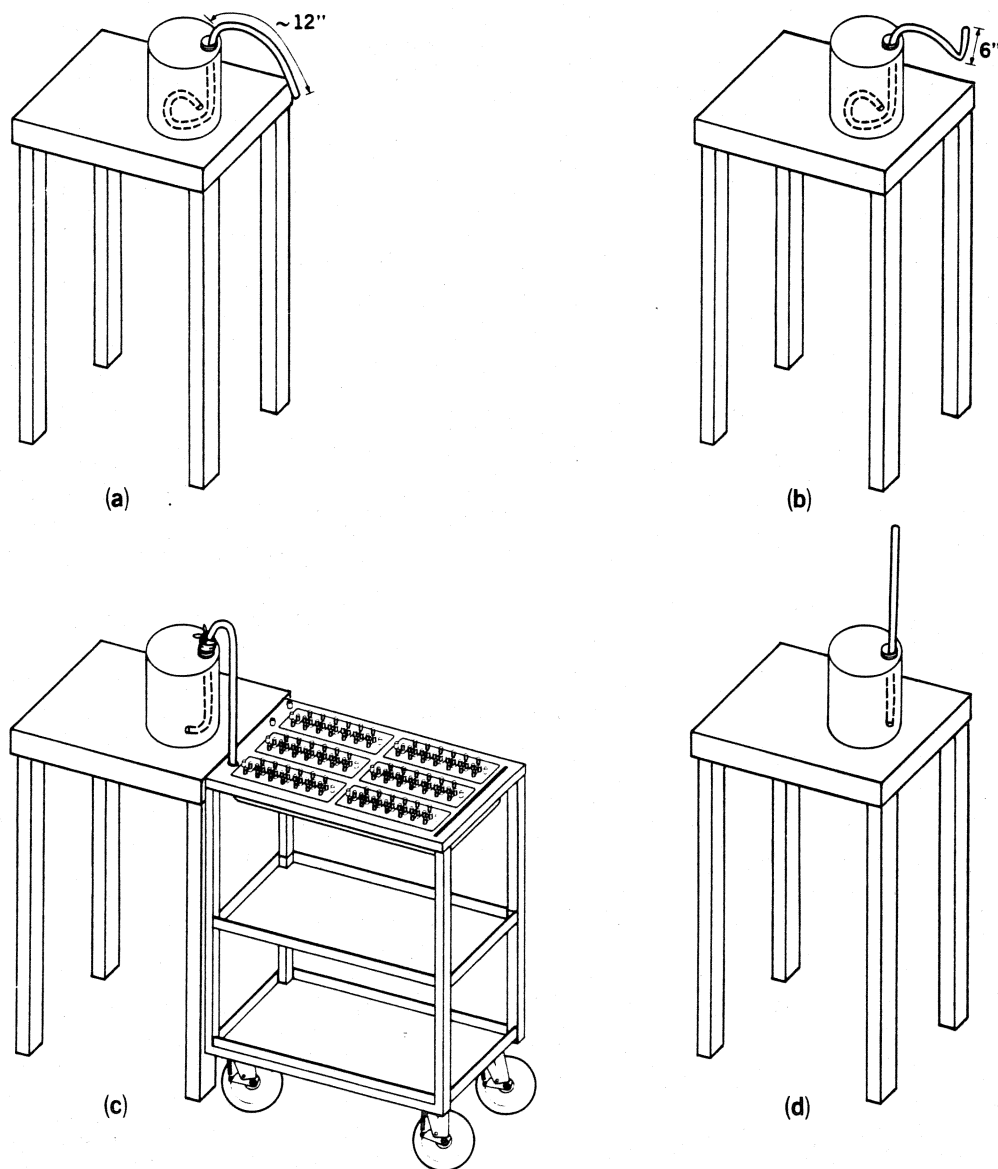

Figure 6-3. Siphoning the Oil

#### 6.1.4 Installing the Calibration Card

The Calibration Card and its protective cover should be connected to the SR1060 Casting by means of a chain that is attached to the cover. Refer to Figure 6-4. The procedure requires the following equipment:

Allen (Hex) Wrench, 3/32 inch

- STEP 1. Unscrew the 6-32 allen (hex) head screw that is to secure the Calibration Card chain.
- STEP 2. Insert the 6-32 screw through the eyelet at the end of the Calibration Card chain.
- STEP 3. Insert the 6-32 screw back in the Casting and tighten it (hand-tight) with the allen wrench.

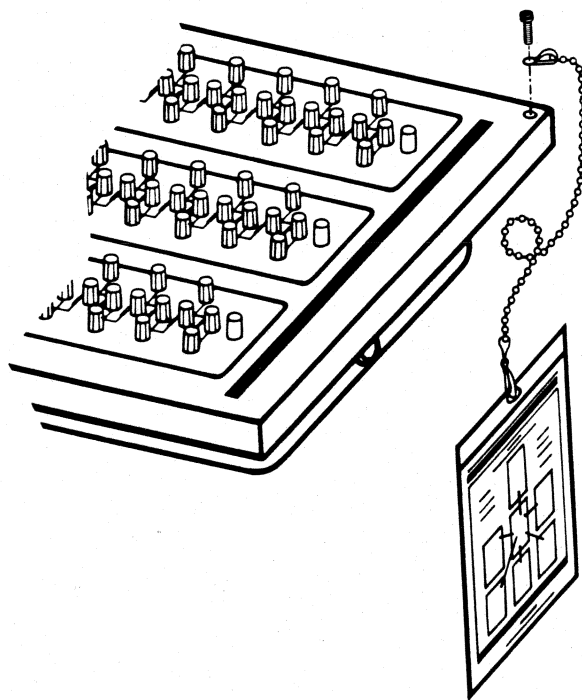

Figure 6-4. Installing the Calibration Card

### 6.1.5 Initial Checkout

The initial checkout consists of measuring the resistance of the Oil between the OIL TEST connectors. The location of these BNC connectors is shown in Figure 6-5. This measurement is made between the center conductor of each connector. A three-terminal (guarded) measurement should be made with the guard connected to the outer connector on both OIL TEST connectors. A measured resistance of less than 1 teraohm ( $10^{12}$  ohm) indicates that the Oil has been contaminated and should be replaced.

Once the initial checkout has been completed, an initial resistance reading of the SR1060 resistors should be made.

**NOTE:** The oil in the SR1060 should be allowed to reach the ambient room temperature before these readings are made. Leaving the SR1060 in the room for 24 hours should allow the Oil to reach room temperature. If the Oil is very cold before being put in the SR1060, 48 hours may be required.

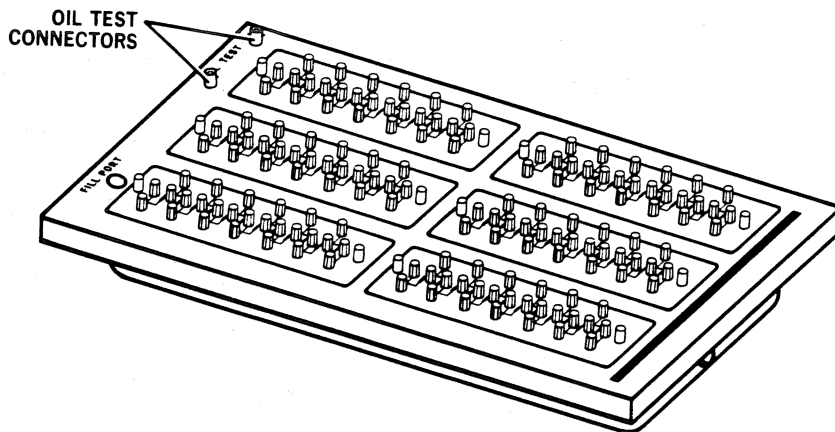

Figure 6-5. Location of OIL TEST Connectors



## 6.2 REPAIR

Because of the careful matching involved, the individual resistors within a resistor bank are not field-replaceable. If a problem is identified within a resistor bank, that particular bank should be returned to ESI for repair, after obtaining a Return Materials Authorization (RMA) number.

### 6.2.1 Returning a Resistor Bank for Repair

If it is necessary to return a Resistor Bank for repair, it must be removed from the SR1060 and properly packaged. A Packing Box must be constructed to hold the Resistor Bank without risk of physical damage to the resistors. This is done as follows.

STEP 1. Before the Resistor Bank is removed for shipment, locate a sturdy cardboard box (with all six sides intact) whose dimensions fall within these ranges:

Height:	2.5 to 4.0 inches (6 to 10 centimeters)
Width:	5.0 to 7.0 inches (12.5 to 17.5 centimeters)
Length:	13.5 to 16.0 inches (340 to 400 centimeters)

STEP 2. Cut a rectangular hole in the center of the top of the box located in STEP 1. The hole should be  $3.0 \pm 0.5$  inches ( $75 \pm 1$  centimeters) wide and  $12.0 \pm 0.5$  inches ( $30.4 \pm 1.2$  centimeters) long. Refer to Figure 6-6.

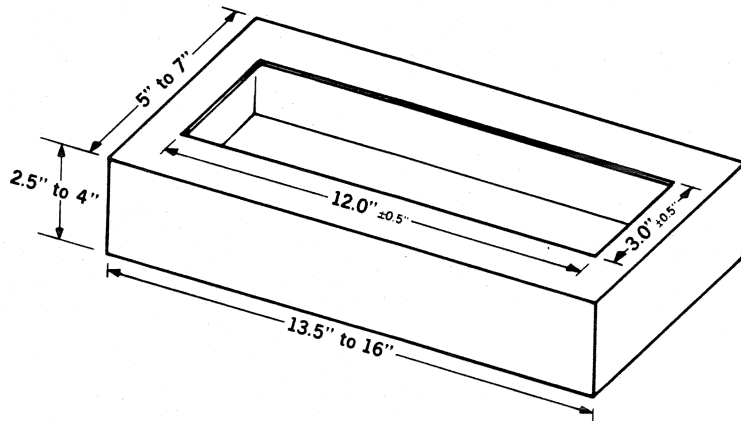

Figure 6-6. Resistor Bank Packing Box

STEP 3. Locate a **clean** plastic bag that is large enough to hold the Resistor Bank without stretching. A width of at least 5 inches (13 centimeters) and a length of at least 16 inches (40 centimeters) should be adequate. This bag will prevent the oil on the resistors from dripping on the packing box.

STEP 4. Remove the 14 allen head (hex socket) screws that hold the particular Resistor Bank in place. Refer to Figure 6-7.

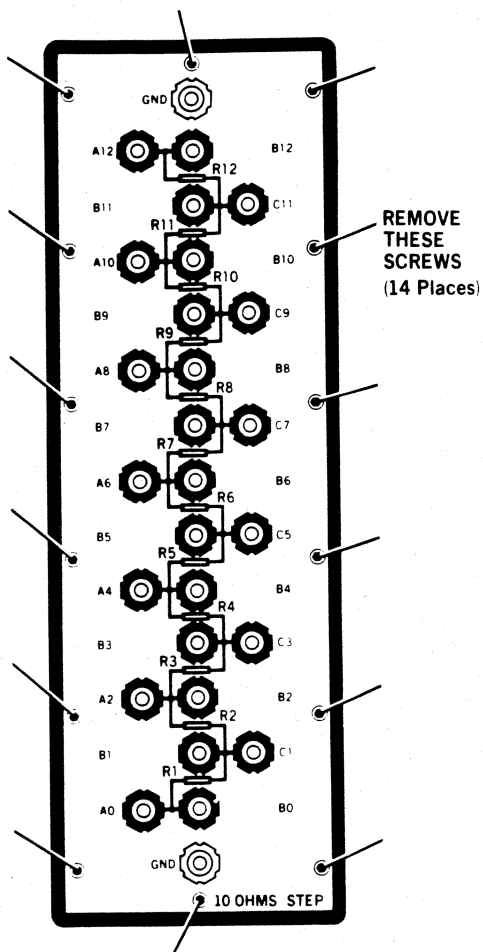

Figure 6-7. Removing the Resistor Bank Screws

**CAUTION**

**EXTREME CAUTION MUST BE FOLLOWED IN THE FOLLOWING STEP TO AVOID CONTACTING THE MAIN CASTING OR TOP PLATE OF THE SR1060 WITH THE RESISTORS. SUCH CONTACT MAY DAMAGE THE RESISTORS.**

- STEP 5. Grasp the Resistor Bank by the terminals and **slowly** lift it from the SR1060.
- STEP 6. Allow most of the oil to drip from the Resistor Bank back into the SR1060. When the dripping has nearly stopped, **carefully** slip the Resistor Bank into the plastic bag discussed in STEP 3. Tie off the open end of the plastic bag to prevent the escape of oil. Refer to Figure 6-8.

**CAUTION**

**EXTREME CAUTION MUST BE FOLLOWED IN THE FOLLOWING STEP TO AVOID CONTACTING THE PACKING BOX WITH THE RESISTORS. IN ADDITION, THE PLASTIC BAG MUST NOT CATCH ON THE BOX. EITHER OF THESE CONDITIONS COULD STRESS THE RESISTORS, WHICH COULD DAMAGE THEM.**

- STEP 7. **Carefully** lower the Resistor Bank through the hole cut in the top of the Packing Box. Refer to Figure 6-8.

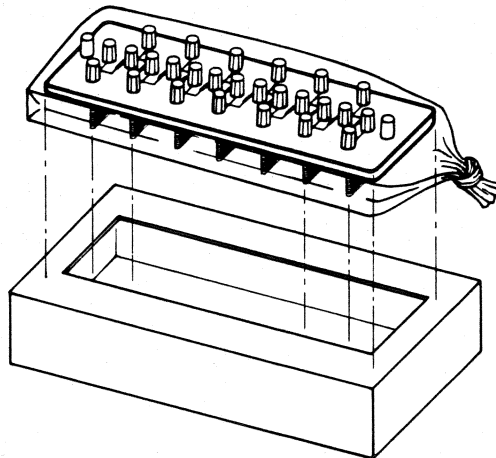

**Figure 6-8. Packing the Resistor Bank**

- STEP 8. Securely tape the Resistor Bank in place in the Packing Box using filament strapping tape. Refer to Figure 6-9. Verify that the Resistor Bank is unable to move in any direction.
- STEP 9. Verify that the Packing Box is sealed such that nothing can enter it.
- STEP 10. Pack the Resistor Bank and Packing Box in a shipping box that allows space for at least 3 inches of packing material around all sides of the Packing Box. The packing material should be firm enough to keep the Resistor Bank and Packing Box from shifting, yet compressible enough to absorb severe shocks. Styrofoam "peanuts" or similar packing material should be adequate if packed tightly.

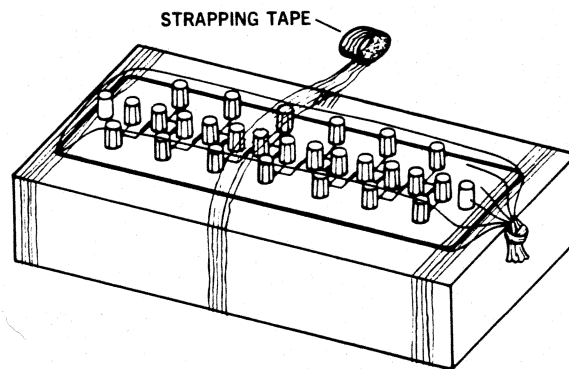

**Figure 6-9. Taping the Resistor Bank to the Packing Box**

**NOTE:** The plate described in the following STEP will not fit and is not required if the 100 kilohm-per-step Resistor Bank is being repaired.

STEP 11. The hole in the SR1060 should be covered to prevent foreign materials from contaminating the Oil. A metal or plastic plate of the dimensions shown in Figure 6-10 could be constructed to serve this function.

STEP 12. Set the cover on the SR1060 in place of the Resistor Bank that has been removed. If a plate has been constructed, use the same screws that held the Resistor Bank in place to secure the plate with screws in the six positions noted by an "X" in Figure 6-10. It is advisable to install the remaining screws to avoid losing them.

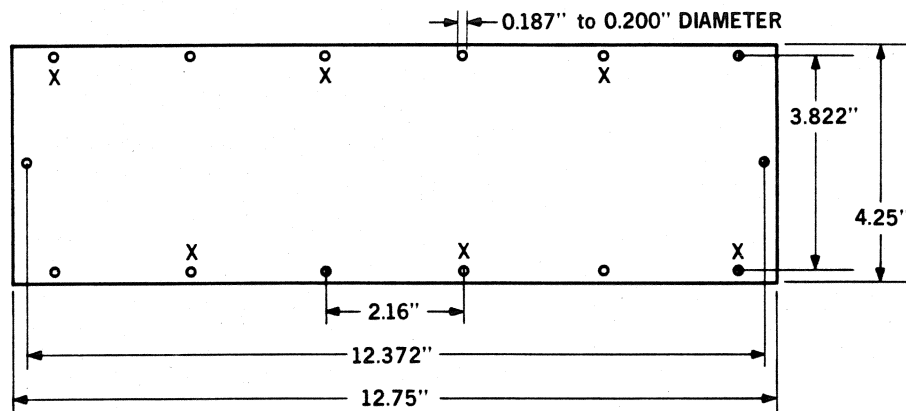

Figure 6-10. Plate to Replace Resistor Bank

## 6.2.2 Installing a Single Resistor Bank

After receiving a repaired Resistor Bank, it must be unpacked and installed in the SR1060. This is done as follows.

- STEP 1. Remove the screws that secure the plate that covers the hole for the Resistor Bank in the SR1060.



**EXTREME CAUTION MUST BE FOLLOWED IN THE FOLLOWING STEP TO AVOID CONTACTING THE RESISTOR BANK WITH THE PACKING BOX, SHIPPING MATERIAL, OR ANY OTHER OBJECTS. SUCH CONTACT MAY DAMAGE THE RESISTORS.**

- STEP 2. Carefully unpack the Resistor Bank from its shipping container. Remove all packing materials from the Bank.



**EXTREME CAUTION MUST BE FOLLOWED IN THE FOLLOWING STEP TO AVOID CONTACTING THE MAIN CASTING OR TOP PLATE OF THE SR1060 WITH THE RESISTORS. SUCH CONTACT MAY DAMAGE THE RESISTORS.**

- STEP 3. Remove the plate whose screws were removed in STEP 1. Carefully lower the Resistor Bank into its place in the SR1060.

- STEP 4. Insert the 14 allen head screws that secure the Resistor Bank in place and hand tighten them. The silver-colored screws and washers must be used with the holes numbered 7 and 8 in Figure 6-11.

- STEP 5. Tighten the allen head screws to 15 inch pounds (1.7 newton meters), following the order indicated in Figure 6-11. This should be done in several passes, tightening the screws about one third of the way on each pass.

- STEP 6. Measure the resistance from a GND terminal on the Resistor Bank that was just replaced to a GND terminal on any other Resistor Bank. If this resistance is less than 100 milliohms, proceed to the next STEP. Otherwise, remove the two silver-colored screws, clean out the threaded holes, and retighten the screws. Repeat this STEP until the resistance is less than 100 milliohms.
- STEP 7. Test the Oil to verify that it has not been contaminated. Refer to Section 6.3.2.1.
- STEP 8. The Resistor Bank should be allowed to stabilize to the temperature of the Oil about 24 hours. After this time, a complete set of measurements of the Resistor Bank should be performed and the results should be recorded on the Calibration Card.

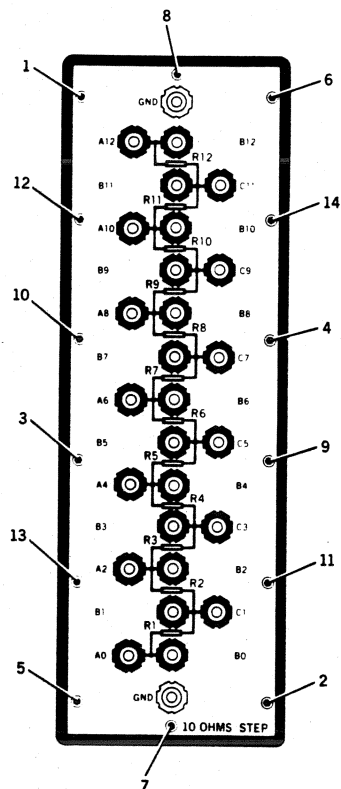

Figure 6-11. Sequence for Tightening the Resistor Bank Screws



### 6.3 Maintenance

The SR1060 was designed to be a stable device that does not require frequent maintenance. The outside of the SR1060 should be cleaned as often as appears necessary. Aside from cleaning, the only maintenance required is checking the accuracy of the individual resistors, and testing the oil for contamination. These two topics are covered in the following sections.

#### 6.3.1 Checking Resistor Accuracy

If the SR1060 is used strictly for resistance transfers, the absolute accuracy of the individual resistors is not significant. If the Series-Parallel connection is used, the deviation from nominal of the the unused resistor (R10) is needed. This deviation should be measured immediately before the resistance transfer is performed.

If the SR1060 is used as a primary resistance standard, a calibration should be performed on a regular basis. A six-month interval between calibrations is recommended. A more frequent schedule of calibration may be desired until a history for the specific SR1060 is obtained that indicates the appropriate interval.

Calibration of the SR1060 is covered in CALIBRATION CARD, Section 3.4.

### 6.3.2 Maintenance of the Oil

The oil in the SR1060 should require replacement only when it has become contaminated. The sealing mechanisms provided in the SR1060 are designed to minimize the chance of such contamination. The following sections describe the maintenance procedures concerning the oil.

#### 6.3.2.1 Testing the Oil for Contamination

Contamination of the oil is identified as too low of a resistance between the OIL TEST terminals. To test for contamination, a three-terminal (guarded) measurement should be made between the center conductors of the OIL TEST connectors, with the Guard connected to the outer conductors. If the resistance is less than one teraohm ( $10^{12}$  ohms), the oil is contaminated and should be replaced.

### 6.3.2.2 Changing the Oil

The oil should be drained as follows.

- STEP 1. Remove the FILL PORT Plug, using a 1/2 inch open-end wrench. The location of this Plug is indicated in Figure 6-12.
- STEP 2. Set a clean container underneath the Drain Plug so that it will catch the oil as it drains. The location of the Drain Plug is indicated in Figure 6-12.

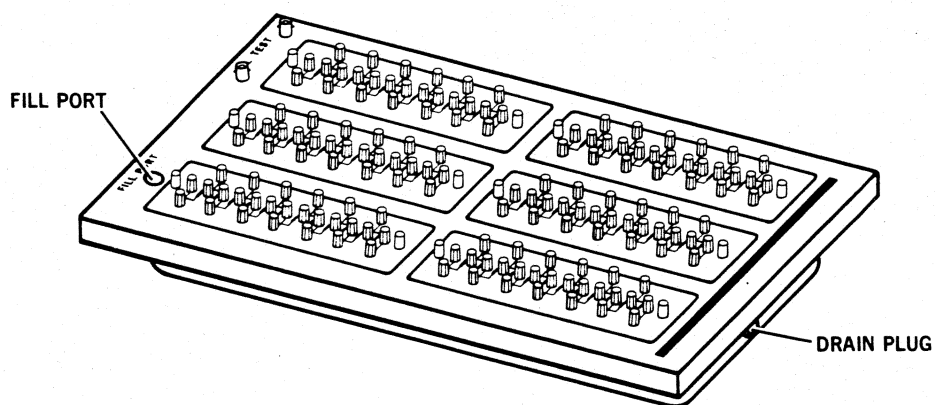

**Figure 6-12. Location of FILL PORT Plug and Drain Plug**

- STEP 3. Remove the Drain Plug using a 5/16 inch allen (hex) wrench, allowing the Oil to drain into the container.

**NOTE:** Units with the following serial numbers: 20108861060, 20208861060, 20308861060, 20408861060, 20508861060, and 20608861060 use the Part Number 58360 Drain Plug, which requires teflon tape for a proper seal. All other units use the Part Number 60154 Drain Plug with "O" Ring. These units do **not** require the teflon tape referred to in the following STEP.

- STEP 4. After draining the contaminated oil, wrap teflon tape around the threads of the Drain Plug and replace it in the SR1060. Tighten the Drain Plug until it is snug, about 75 inch pounds (8.5 newton meters).
- STEP 5. Refill the SR1060 with oil as described in Refilling the SR1060 with Oil, Section 6.1.3.

#### 6.3.2.3 Disposing Contaminated Oil

Before disposing of oil, all Local, State, and Federal regulations as they may apply should be reviewed to determine approved disposal procedures.

#### 6.3.2.4 Purchasing Oil

The oil can be obtained from ESI as Part Number 62414. It is manufactured by Penreco (of Dickinson Texas) as Sontex 85, white. The distributor is Van Waters and Rogers.

#### 6.3.2.5 Cleaning Up Oil Spills

The oil tends to spread very easily if it is not cleaned up immediately. For this reason, it is suggested that great care be taken to ensure that the oil is kept in securely closed containers. In case the Oil does spill, the bulk of it should be wiped up with an ordinary rag or paper towel. This should be disposed of in accordance with all local, state, and federal regulations.

#### 6.3.2.6 Material Safety Data Sheet for Oil

A Material Safety Data Sheet for the oil is included with the SR1060.



## SECTION 7 PARTS LISTS

### 7.1 SR1060 (P/N 31060)

Two different Castings have been used in the SR1060. Units with serial numbers 20108861060, 20208861060, 20308861060, 20408861060, 20508861060, and 20608861060 use the Casting that is no longer available. To order replacement parts (except for the Casting) for units with these serial numbers, refer to Section 7.1.1. To order the Casting for these units, order Part Number 58005 and replace the following parts:

Drain Plug, Part Number 60154  
Screw, Allen Head, 8-32 x 0.875, Black (12), Part Number 60290  
Screw, Allen Head, 8-32 x 0.875 (2), Part Number 60344  
Screw, Allen Head, 10-32 x 1.000 (42), Part Number 60291

To order replacement parts for other units, refer to Section 7.1.2.

## 7.1.1 Parts List\*

DESCRIPTION	ESI PART NUMBER
Casting (See Section 7.1)	
Top Plate	58007
Resistor Bank, 1.0 ohm-per-step	58139
Resistor Bank, 10 ohm-per-step	58140
Resistor Bank, 100 ohm-per-step	58135
Resistor Bank, 1 kilohm-per-step	58136
Resistor Bank, 10 kilohm-per-step	58137
Resistor Bank, 100 kilohm-per-step	58138
Plug, Drain	58360
Oil, Mineral	62414
Card, Calibration	58620
Holder, Calibration Card	59878
"O" Ring, Oil Fill	60240
"O" Ring, 26.974 x 0.139 inch	58362
"O" Ring, 9.388 x 0.139 inch (5)	58363
"O" Ring, 9.867 x 0.139 inch (used with 100 kilohm-per-step Resistor Bank)	58364
Screw, Allen Head, 8-32 x 0.750 (12), Black	50548
Screw, Allen Head, 8-32 x 0.750 (2)	60343
Screw, Allen Head, 10-32 x 0.750 (42)	50551
Screw, Allen Head (Hex Socket), 8-32 x 0.375 (60), Black	50543
Screw, Allen Head (Hex Socket), 8-32 x 0.375 (10)	60342
Screw, Allen Head, 1/4-20 x 1.25 (4)	50480
Screw, Allen Head, 6-32 x 0.250 (for Calibration Card)	50293
Blank, Resistor	58555
Connector, BNC (2)	13255
Washer, Lock, #8, Black (72)	60293
Washer, Lock, #8 (12)	03584
Washer, Lock, #10 (42)	60292
Nut, 1/4-20 (4)	03530
Washer, Internal Tooth, 1/4 inch (4)	03592
Plug, Oil Fill, with Temperature Well	59466
Kit, Accessory	59871

\*For units with serial numbers 20108861060, 20208861060, 20308861060, 20408861060, 20508861060, and 20608861060



## 7.1.2 Parts List\*

DESCRIPTION	ESI PART NUMBER
Casting	58005
Top Plate	58007
Resistor Bank, 1.0 ohm-per-step	58139
Resistor Bank, 10 ohm-per-step	58140
Resistor Bank, 100 ohm-per-step	58135
Resistor Bank, 1 kilohm-per-step	58136
Resistor Bank, 10 kilohm-per-step	58137
Resistor Bank, 100 kilohm-per-step	58138
Plug, Drain, with "O" Ring	60154
Oil, Mineral	62414
Card, Calibration	58620
Holder, Calibration Card	59878
"O" Ring, Drain Plug	60153
"O" Ring, Oil Fill	60240
"O" Ring, 26.974 x 0.139 inch	58362
"O" Ring, 9.388 x 0.139 inch (5)	58363
"O" Ring, 9.867 x 0.139 inch (used with 100 kilohm-per-step Resistor Bank)	58364
Screw, Allen Head, 8-32 x 0.875 (12), Black	60290
Screw, Allen Head, 8-32 x 0.875 (2)	60344
Screw, Allen Head, 10-32 x 1.000 (42)	60291
Screw, Allen Head (Hex Socket), 8-32 x 0.375 (60), Black	50543
Screw, Allen Head (Hex Socket), 8-32 x 0.375 (10)	60342
Screw, Allen Head, 1/4-20 x 1.25 (4)	50480
Screw, Allen Head, 6-32 x 0.250 (for Calibration Card)	50293
Blank, Resistor	58555
Connector, BNC (2)	13255
Washer, Lock, #8, Black (72)	60293
Washer, Lock, #8 (12)	03584
Washer, Lock, #10 (42)	60292
Nut, 1/4-20 (4)	03530
Washer, Internal Tooth, 1/4 inch (4)	03592
Plug, Oil Fill, with Temperature Well	59466
Kit, Accessory	59871

\*For units with serial numbers other than 20108861060, 20208861060, 20308861060, 20408861060, 20508861060, and 20608861060

**7.2 ACCESSORY KIT (P/N 59871)**

**DESCRIPTION**

Cover, Dust  
Manual, Instruction  
Chain, Calibration Card

**ESI PART NUMBER**

58515  
58619  
59870

**7.3 OPTIONS**

**DESCRIPTION**

Cart  
PC101 Parallel Compensation Network  
SB103 Shorting Bars  
SPC102 Series-Parallel Compensation Network

**ESI PART NUMBER**

58359  
08540  
08551  
08560

## WARRANTY OF QUALITY

Electro Scientific Industries, Inc. warrants its products to be free from defects in material and workmanship. Rigorous quality control permits the following standard new equipment warranties:

1. Two years for components and instruments utilizing passive circuitry.
2. One year on components and instruments utilizing active circuitry. One year on test fixtures.

During the in-warranty periods, we will service or, at our option, replace, at the factory, any device that fails in normal use to meet its published specifications. Batteries, tubes and relays that have given normal service are excepted.

## WARRANTY OF TRACEABILITY

The reference standards of measurement of Electro Scientific Industries, Inc., are compared with the U.S. National Standards through frequent tests by the U.S. National Institute of Standards and Technology. The ESI working standards and testing apparatus used are calibrated against the reference standards in a rigorously maintained program of measurement control.

The manufacture and final calibration of all ESI instruments are controlled by use of the ESI reference and working standards and testing apparatus in accordance with established procedures and documented results. (Reference MIL-C-45662)

## DISCLAIMER OF IMPLIED WARRANTIES

THE FOREGOING WARRANTIES OF ESI ARE IN LIEU OF ALL OTHER WARRANTIES, EXPRESS OR IMPLIED. ESI SPECIFICALLY DISCLAIMS ANY IMPLIED WARRANTIES OF MERCHANTABILITY OR FITNESS FOR A PARTICULAR PURPOSE. In no event will ESI be liable for special or consequential damages. Purchaser's sole and exclusive remedy in the event any item fails to comply with the foregoing express warranties of ESI shall be to return the item to ESI, shipping charges prepaid, and at the option of ESI obtain a replacement item or a refund of the purchase price.

Where ESI product will interconnect with components not supplied by ESI, ESI does not warrant the ESI product against failures caused by mismatch of the non-ESI component to the ESI product nor will ESI be liable for damages to the non-ESI component resulting from mismatch.



Electro Scientific Industries, Inc.

13900 N.W. Science Park Drive • Portland, Oregon 97229 • Telephone: (503) 641-4141 • Telex 4742064





## ESI technical publications

ESI wants to provide you with instruction manuals that contain the information you need to do your job. That is why we have devised this survey. Your answers will help us as we revise the manuals you are now using and help us plan better manuals in the future.

First, we need to know something about you. We need to know a little about your job, your background, and your experience. This will help us to better understand your comments about a specific manual and to better design our manuals to satisfy your needs. The second part of this survey asks for your comments about a specific manual.

This survey form is bound in the back of every ESI manual. Please, let us know how we're doing.

When completed, fold, staple, and mail to ESI. The address and postage are included on the reverse side.

NAME \_\_\_\_\_

COMPANY \_\_\_\_\_

ADDRESS \_\_\_\_\_

CITY \_\_\_\_\_

STATE/COUNTRY \_\_\_\_\_

ZIP \_\_\_\_\_

## User survey

- What is your job title and function? (setup, service, operation, site management, etc.) \_\_\_\_\_
- What is your background?
  - Your education/training/degree? \_\_\_\_\_
  - Your area of specialization? \_\_\_\_\_
- Is your place of employment  Small (less than 500 employees)  Large (more than 500 employees)  An academic institution
- Is this your first experience with ESI instrumentation?  YES  NO (If NO, which other products (model number) \_\_\_\_\_, how many years of such experience \_\_\_\_\_)
- Rate your familiarity with electronic repair and troubleshooting
  - POOR  AVERAGE  GOOD  EXCELLENT
- Is English your native language?  YES  NO
  - If NO, rate your English reading skill
  - POOR  AVERAGE  GOOD  EXCELLENT

## Instruments manual evaluation

- Manual title and part number \_\_\_\_\_
- How long have you had this manual? \_\_\_\_\_
- Your initial reaction to this manual was
  - POOR  FAIR  GOOD  EXCELLENT
- How frequently do you use this manual?
  - ONCE  A LITTLE  FAIRLY OFTEN  OFTEN
- Did the manual contain the information you needed?  YES  NO

If NO, what would you add \_\_\_\_\_

- Did the organization of the manual help you locate the information you needed?
  - YES  NO
- Were there too many or too few examples?
  - TOO MANY  TOO FEW  ABOUT RIGHT
- Did the examples help you understand the information?  YES  NO
- Was the writing in the manual
  - HARD TO UNDERSTAND  AVERAGE  EASY TO UNDERSTAND
- Was the tone of the manual
  - STILTED  NEUTRAL  FRIENDLY  PATRONIZING
- Was the level of the information
  - OVERSIMPLIFIED  ABOUT RIGHT  TOO TECHNICAL
- Was the organization of the manual
  - ILLOGICAL, HARD TO FOLLOW  LOGICAL, EASY TO FOLLOW
- Did you like the binding of the manual?  YES  NO

If NO, what would you prefer \_\_\_\_\_

- Did you find any defects in the printing or binding of the manual?
  - YES  NO
- If YES, what were the problems \_\_\_\_\_
- How would you compare ESI's manuals with those of other manufacturers?
  - WORSE  SAME  BETTER  CANNOT COMPARE
- Compared to which manufacturer? \_\_\_\_\_

**Electro Scientific Industries, Inc.**  
13900 N.W. Science Park Drive  
Portland, Oregon 97229

POSTAGE WILL BE PAID BY ADDRESSEE

FIRST CLASS PERMIT NO. A-649 PORTLAND, OR, U.S.A.

**BUSINESS REPLY MAIL**

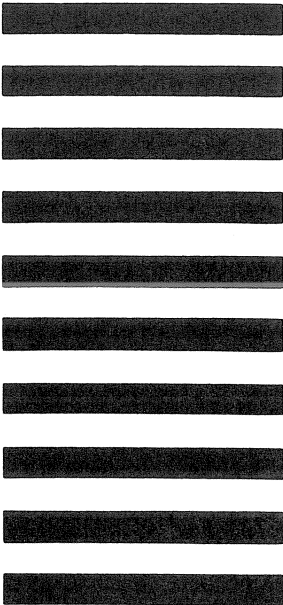
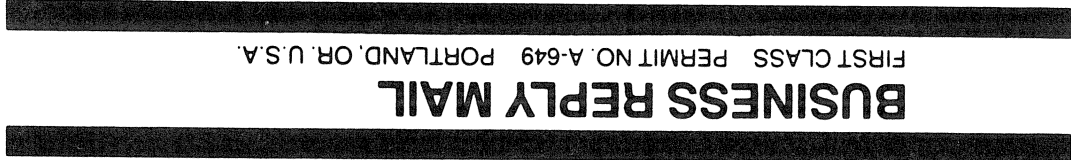

NO POSTAGE  
NECESSARY  
IF MAILED  
IN THE  
UNITED STATES

